

Verso S 2100 F C5

Nominal air flow, m ³ /h	1935
Nominal air flow, l/s	538
Electric power input of the fan drive at reference flow rate, W	340
Filters dimensions BxHxL, mm	858x287x46
Unit dimensions BxHxL, mm	1000x350x893
Panel thickness, mm	50
Maintenance space, mm	400
Unit weight, kg	73



Acoustic data

A-weighted sound power level L_{WA} , dB(A)
at nominal flow rate

Supply inlet	70
Supply outlet	75
Casing	52

A-weighted sound pressure level L_{PA} , dB(A)

10 m² normally isolated room, distance from casing – 3 m.

Surroundings	41
--------------	----

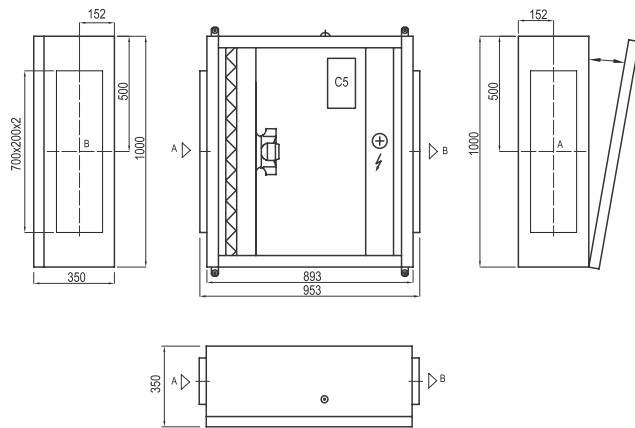

Technical data

Supply air handling unit	Supply voltage, V	Air heater capacity, kW	Maximal operating current, A	ΔT , °C
Verso S 2100 F-HE/15	3~400	15,0	24,7	22,7
Verso S 2100 F-HE/22,5	3~400	22,5	35,6	34,0
Verso S 2100 F-HW	1~230	-	3,3	-

Performance

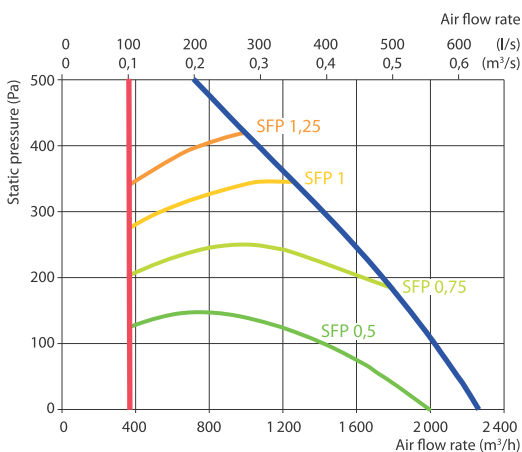

* Compliance to ErP2018 requirements check with the selection program.

Hot water air heater

Water temperature in/out, °C	80/60	70/50	60/40
Capacity, kW	17,8	15	12,2
Flow rate, dm ³ /h	780	657	533
Pressure drop, kPa	6,1	4,5	3,1
Temperature in/out, °C	-5,0 / 22,3	-5 / 17,4	-5 / 13,8
Maximal capacity, kW	17,8	15	12,2
Connection, "		½	

Accessories

Closing damper	SRU-M-700x200+LF24/LM24
Silencer	A STS-IVR3BA-800-250-700-S
	B STS-IVR3BA-800-250-1250-S
PPU	PPU-HW-3R-15-2.5-W2
Air heater-cooler	DCW-2,0-13
2-way valve	VVP47.20-4,0+SSP61
DX cooler	DCF-2,0-14
Cooling unit	MOU-48HFN8+KA8243

Mounting positions

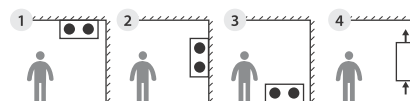

2 3 4
with water heater only