

# COMPACT VENTILATION UNIT LG 150



LG 150 A,  
LG 150 AF



LG 150 A,  
LG 150 AF

EN 13141-7:2011  
LG 150 A,  
LG 150 AF,  
LG 150 B,  
LG 150 BF



LG 150 A,  
LG 150 AF



EU Regulation  
1253/2014

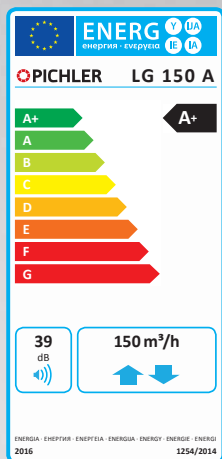

The specified energy efficiency is applicable when controlled to local requirements and is valid up to the specified maximum air flow volume.

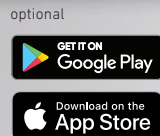
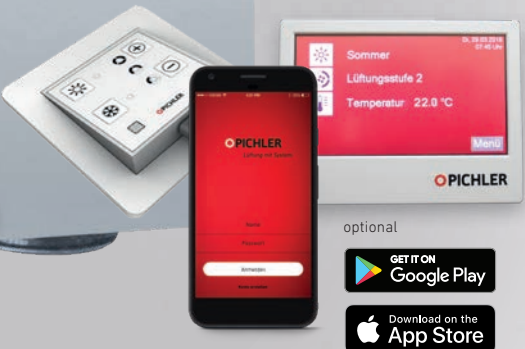

Systematic ventilation.

## Product description

The compact ventilation unit LG 150 consists of a compact EPP-housing with equipment cladding that is free of thermal bridges and is thermally insulated, externally powder-coated in RAL 9003, a high efficiency heat recovery system with an air/air

counterflow heat exchanger made of recyclable plastic with up to app. 95 % efficiency with an automatic 100 % bypass, with energy-saving radial fans with DC technology with constant volume flow control, filters ODA ISO ePM2,5 55% in the outdoor air and ETA

filters ISO Coarse 70% in the extract air, integrated cabled control electronics, with an optional MINI or TOUCH (optional) operating control unit and with an inspection door for filter servicing such as a connection to the Internet (LAN connection) via the Pichler app.

## Area of application

The compact ventilation unit LG 150 is used for the controlled mechanical supply and exhaust air ventilation of apartments in multi-storey buildings, smaller residential units and similar applications.

Regarding the LG 150 A the range of use extends fundamentally to residential areas of 40 m<sup>2</sup> to approx. 120 m<sup>2</sup> that are designed as passive or low energy structures, with an adjustable air volume flow up to 150 m<sup>3</sup>/h.

Regarding the LG 150 B with high ventilation system performance it extends fundamentally to residential areas to approx. 160 m<sup>2</sup> with an adjustable air volume flow up to 200 m<sup>3</sup>/h.

## Layout sketch (wall-mounted or ceiling-mounted installation, right-hand-version)

Dimensions: (W x H x D) 680 x 783 x 290 mm

Air line connection: 4 x Ø 125 mm

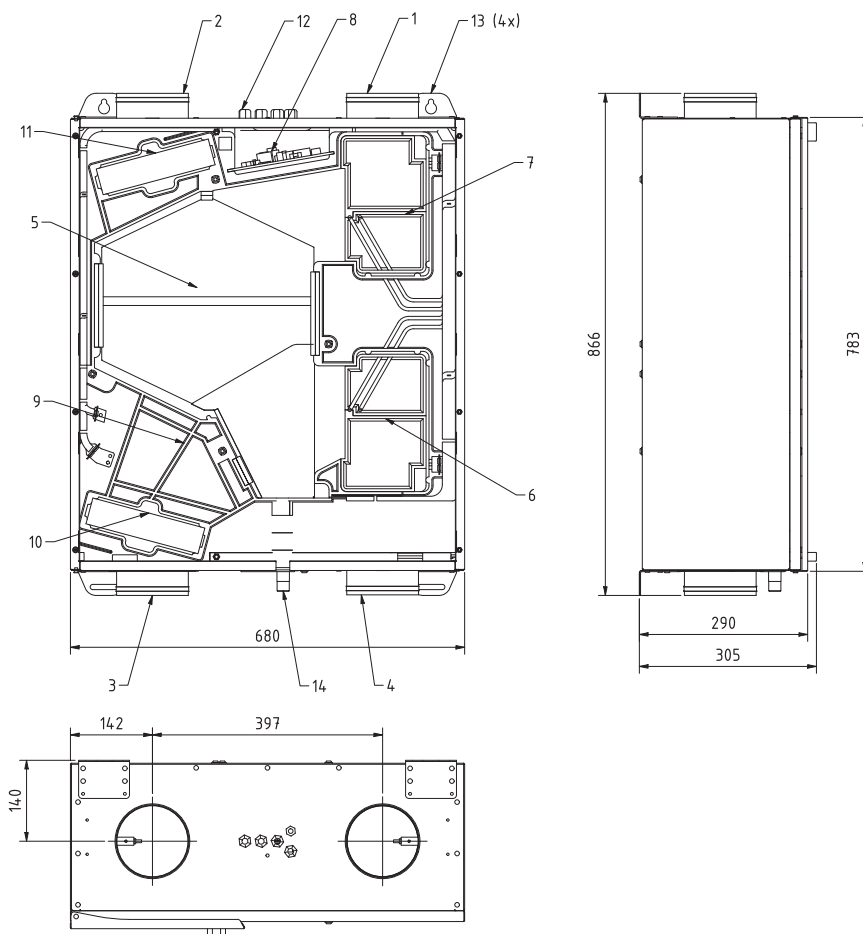

- 1 Supply air ø 125 mm
- 2 Extract air ø 125 mm
- 3 Outdoor air ø 125 mm
- 4 Exhaust air ø 125 mm
- 5 Counterflow heat exchanger with condensate tray
- 6 Exhaust air fan
- 7 Supply air fan
- 8 Control system
- 9 Bypass flap with preheater battery (optional)
- 10 Filter ODA ISO ePM2,5 55%
- 11 Filter ETA ISO Coarse 70%
- 12 Cable inlets
- 13 Mounting bracket
- 14 Condensate outlets R1/2" AG

**Illustration:**  
LG 150 AWR (right-hand version)  
(also applicable to LG 150 B)



## Layout sketch (wall-mounted or ceiling-mounted installation, left-hand-version)

Dimensions: (W x H x D) 680 x 783 x 290 mm

Air line connection: 4 x Ø 125 mm

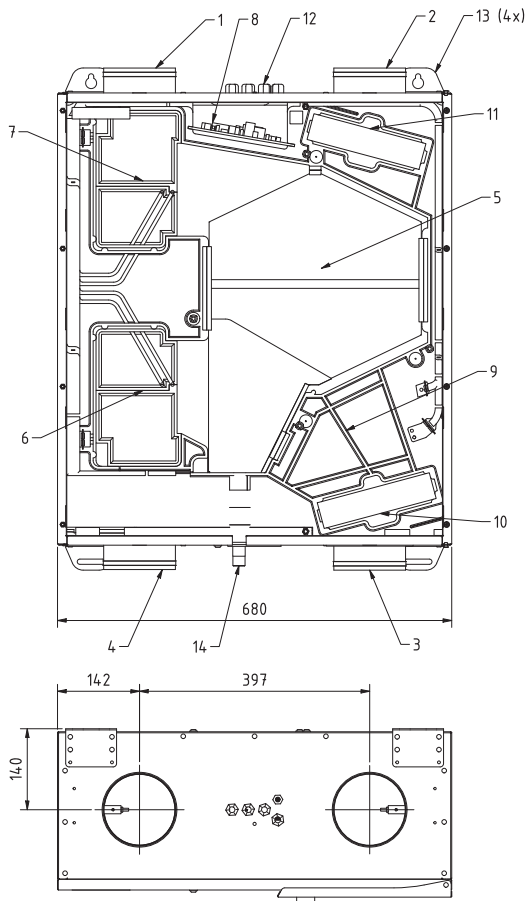

- 1 Supply air ø 125 mm
- 2 Extract air ø 125 mm
- 3 Outdoor air ø 125 mm
- 4 Exhaust air ø 125 mm
- 5 Counterflow heat exchanger with condensate tray
- 6 Exhaust air fan
- 7 Supply air fan
- 8 Control system
- 9 Bypass flap with preheater battery (optional)
- 10 Filter ODA ISO ePM2,5 55%
- 11 Filter ETA ISO Coarse 70%
- 12 Cable inlets
- 13 Mounting bracket
- 14 Condensate outlets R1/2" AG

Illustration:  
LG 150 AWL (left-hand version)  
(also applicable to LG 150 B)



## Versions

The compact ventilation unit LG 150 is available in several different versions:

- right-hand or left-hand, depending on the location of the supply air connecting piece
- with or without an integrated PTC heater battery (frost protection for the counterflow heat exchanger)
- with a standard or an enthalpy exchanger for moisture recovery

Advantages of the enthalpy exchanger:

Humidity-transferring counter flow enthalpy exchanger with selective polymer membrane for heat and moisture recovery.

- Enthalpy exchangers ensure optimal comfort within your rooms.
- During normal operation, the generation of condensate is prevented as far as possible.
- In contrast to a standard heat exchanger, the enthalpy exchanger only stops at low temperatures.
- The enthalpy exchanger prevents your rooms from drying out in winter.

### LG 150 A AND LG 150 B

Wall-mounted version LG 150 A	Left-hand version	Right-hand version
Item no. without an integrated PTC heater battery	08LG150AWL	08LG150AWR
Item no. with an integrated PTC preheater battery	08LG150AWLV	08LG150AWRV
Item no. without an integrated PTC heater battery and with an enthalpy exchanger for moisture recovery	08LG150AWLF	08LG150AWRF
Item no. with an integrated PTC heater battery and with an enthalpy exchanger for moisture recovery	08LG150AWLFV	08LG150AWRFV

Wall-mounted version LG 150 B	Left-hand version	Right-hand version
Item no. without an integrated PTC heater battery	08LG150BWL	08LG150BWR
Item no. with an integrated PTC preheater battery	08LG150BWLTV	08LG150BWRV
Item no. without an integrated PTC heater battery and with an enthalpy exchanger for moisture recovery	08LG150BWLTF	08LG150BWRF
Item no. with an integrated PTC heater battery and with an enthalpy exchanger for moisture recovery	08LG150BWLTFV	08LG150BWRFV
Wall mounted		

Ceiling-mounted version LG 150 A (in final assembly min. 2 % inclined assembled)	Left-hand version	Right-hand version
Item no. without an integrated PTC heater battery	08LG150ADL	08LG150ADR
Item no. with an integrated PTC preheater battery	08LG150ADLV	08LG150ADRV
Item no. without an integrated PTC heater battery and with an enthalpy exchanger for moisture recovery	08LG150ADLF	08LG150ADRF
Item no. with an integrated PTC heater battery and with an enthalpy exchanger for moisture recovery	08LG150ADLFV	08LG150ADRFV

Ceiling-mounted version LG 150 B (in final installation min. 2 % inclined assembled)	Left-hand version	Right-hand version
Item no. without an integrated PTC heater battery	08LG150BDL	08LG150BDR
Item no. with an integrated PTC preheater battery	08LG150BDLV	08LG150BDRV
Item no. without an integrated PTC heater battery and with an enthalpy exchanger for moisture recovery	08LG150BDLTF	08LG150BDRF
Item no. with an integrated PTC heater battery and with an enthalpy exchanger for moisture recovery	08LG150BDLTFV	08LG150BDRFV
Ceiling mounted		



1 Supply air



2 Extract air



3 Outdoor air





4 Exhaust air

## Technical specifications

Unit type	LG 150 A (V)	LG 150 AF (V)	LG 150 B (V)	LG 150 BF (V)
Heat exchanger	Standard	Enthalpy exchanger	Standard	Enthalpy exchanger
Air volume flow min. – max. (adjustable in 5 m <sup>3</sup> /h intervals)	30 – 150 m <sup>3</sup> /h	30 – 150 m <sup>3</sup> /h	30 – 200 m <sup>3</sup> /h	30 – 200 m <sup>3</sup> /h

Characteristic values as per EN13141-7:2010				
Temperature ratio $\eta_{\theta, SU}^1$	92,4 %	84,2 %	92,5 %	83,4 %
Temperature ratio $\eta_{\theta, EX}^1$	79,4 %	71,5 %	79,4 %	66,5 %
Specific power input SPI	0,25 Wh/m <sup>3</sup>	0,24 Wh/m <sup>3</sup>	0,41 Wh/m <sup>3</sup>	0,36 Wh/m <sup>3</sup>
External leakage	< 1,05 %	< 1,05 %	< 0,87 %	< 2,06 %
Internal leakage	< 0,86 %	< 0,76 %	< 0,71 %	< 0,63 %

Characteristic values based on PHI criteria				
Application range based on PHI	80 – 111 m <sup>3</sup> /h		–	
Heat recovery efficiency $\eta_{\text{eff, heat rec}}$	86 %	83 %	–	–
Application range based on PHI				
Moisture recovery 2	–	71 %	–	–
Electricity efficiency $\eta_{\text{elec}}$	0,30 Wh/m <sup>3</sup>		–	
Power consumption in standby mode	< 1,0 W			

Classification of air filters in accordance with EN ISO 16890	
 ODA filter (outdoor air)	ISO ePM2,5 55 %
 ETA filter (extract air)	ISO Coarse 70 %

Operating conditions	
Permissible ambient temperature (installation location)	+5 to +40 °C
Permissible operating temperature (outdoor air)	-15 to +35 °C

Electrical system	
Electrical connection	230 V / 1 ~ / 50 Hz / 13 A
IP classification	IP20 with connected air ducts
Max. power without preheater battery	168 W
Max. power with preheater battery	918 W

Materials	
Inner part	EPP and galvanized sheet steel
Housing	Galvanised sheet steel powder-coated in RAL 9003
Heat exchanger	Polystyrene
Enthalpy exchanger	Polymer membrane

Housing	
Air line connections	4 x Ø 125 mm
Condensate drain	R 1/2" external thread below
Dimensions (W x H x D)	680 x 783 x 290 mm
Weight without optional accessories	approx. 30 kg

<sup>1</sup>with 70 % of the max. volume flow



## External pressure boost characteristics – air flow rate

The characteristic curves shown are valid for the device version with outdoor air filter class ISO ePM2.5 55% and extract air filter class ISO Coarse 70%, as well as the design with the PTC preheater battery. The characteristic indicates the external

pressure ( $p_{ext.}$ ) available for the duct system. The specified total electrical output takes into account the power consumption for the two fans in the supply and extract air as well as the power consumption of the control.

### MAXIMUM OPERATING POINT

Volume flow: 150 m<sup>3</sup>/h  
Ext. pressure: 200 Pa

### CHARACTERISTICS ACCORDING TO EN13141-7

Nominal air volume flow: 105 m<sup>3</sup>/h  
Housing tightness: external leakage 0.6% and internal leakage 0.7%  
Temperature ratio on the supply air side with standard exchanger: 92.4%  
Temperature ratio on the supply air side with enthalpy exchanger: 84.2%  
Humidity ratio on the supply air side with enthalpy exchanger: 61.7%  
Specific input power: 0.25 Wh/m<sup>3</sup>

### MAXIMUM OPERATING POINT

Volume flow: 200 m<sup>3</sup>/h  
Ext. pressure: 200 Pa

### CHARACTERISTICS ACCORDING TO EN13141-7

Nominal air volume flow: 125 m<sup>3</sup>/h  
Housing tightness: external leakage 1.3% and internal leakage 0.4%  
Temperature ratio on the supply air side with standard exchanger: 90.9%  
Temperature ratio on the supply air side with enthalpy exchanger: 83.4%  
Humidity ratio on the supply air side with enthalpy exchanger: 56.9%  
Specific input power: 0.38 Wh/m<sup>3</sup>

PRESSURE VOLUME FLOW CHARACTERISTIC CURVE FOR LG 150 A

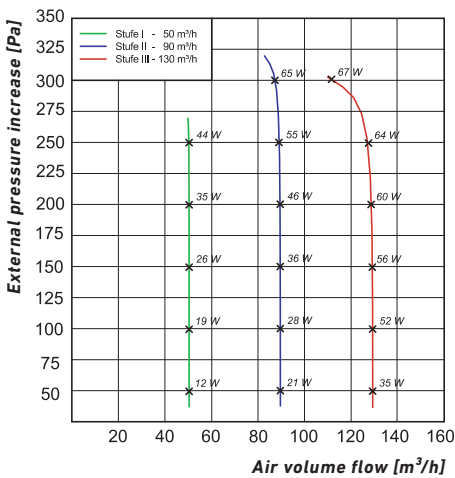

PRESSURE VOLUME FLOW CHARACTERISTIC CURVE FOR LG 150 B

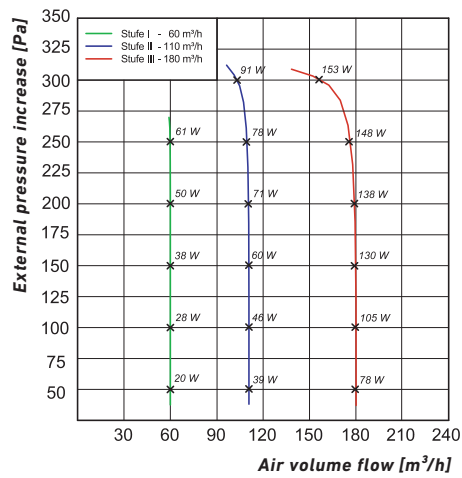

ACOUSTIC SPECIFICATIONS

LG 150 A	Measuring point	Housing emission			Outdoor air connecting piece			Supply air connecting piece			Exhaust air connecting piece			Extract air connecting piece			
100 Pa	Speed	I	II	III	I	II	III	I	II	III	I	II	III	I	II	III	
	63 Hz	L <sub>w</sub> in dB	51	48	47	62	64	66	64	66	68	62	64	66	63	65	67
	125 Hz		44	46	45	44	47	49	57	60	61	55	58	59	43	46	48
	250 Hz		41	42	43	43	46	48	57	60	61	58	61	62	48	51	52
	500 Hz		42	42	42	37	40	41	54	56	58	54	56	58	43	45	47
	1000 Hz		37	39	39	31	33	35	55	58	60	54	56	58	34	37	38
	2000 Hz		<20	22	37	23	26	28	47	50	52	45	48	49	25	28	29
	4000 Hz		<20	<20	21	15	17	19	39	42	43	36	39	41	16	18	20
	8000 Hz		<20	<20	<20	17	20	22	31	33	35	28	31	32	18	20	22
Total L <sub>WA</sub> in dB (A)	42	43	44	41	43	45	58	61	62	57	60	61	44	47	48		
50 Pa	Total L <sub>WA</sub> in dB (A)	36	38	43	36	38	40	53	56	57	52	54	56	39	42	43	

(with an external pressure increase of 100 Pa and 50 Pa)

Remark: Tolerances ± 2 dB for acoustic data

LG 150 B	Measuring point	Housing emission			Outdoor air connecting piece			Supply air connecting piece			Exhaust air connecting piece			Extract air connecting piece			
100 Pa	Speed	I	II	III	I	II	III	I	II	III	I	II	III	I	II	III	
	63 Hz	L <sub>w</sub> in dB	55	56	56	77	78	77	82	83	84	80	82	83	75	79	78
	125 Hz		50	54	57	55	58	62	71	79	79	72	75	76	55	59	63
	250 Hz		37	44	52	55	56	60	67	70	73	65	68	70	55	56	59
	500 Hz		40	46	50	47	44	48	59	64	66	60	63	64	41	43	47
	1000 Hz		33	37	44	37	38	41	59	61	63	56	61	62	36	38	41
	2000 Hz		27	33	41	25	27	32	49	55	59	47	55	58	20	26	31
	4000 Hz		<20	23	30	17	18	24	42	50	54	41	50	53	18	19	24
	8000 Hz		<20	<20	<20	20	19	19	38	45	49	34	45	48	20	17	19
Total L <sub>WA</sub> in dB (A)	40	46	51	53	54	55	65	69	70	64	68	69	52	55	56		
50 Pa	Total L <sub>WA</sub> in dB (A)	34	40	51	47	48	49	59	63	64	58	61	63	46	49	50	

(with an external pressure increase of 100 Pa and 50 Pa)

Remark: Tolerances ± 2 dB for acoustic data





MINI control unit



TOUCH control unit

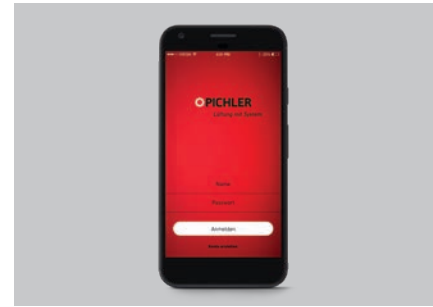

Pichler-App

## Operation

### BYPASS FOR HEAT EXCHANGER

The 100% bypass is controlled as a function of the preset room temperature, the measured extract air temperature and the outdoor air temperature. As a result the heat exchanger can be circumvented in the summer and the cold outdoor air blown out either directly or via the earth collector into the living space.

### CONTROL UNIT

The controller allows scalable configurations from low-cost to high-end. Further options comprise linking to an external building control system via Modbus RTU and sensors to monitor room air quality.

The settings on the ventilation unit are made via an operating control unit, which is supplied complete with the ventilation unit. For the purpose of triggering an operating the ventilation unit the operating control unit MINI or TOUCH (optional) can be selected.

Optionally, a gateway for the KNX bus system is also available.

### MINI

The operating control unit MINI is for the purpose of activating the ventilation unit. It is easy to operate and allows setting of the fan speeds, switching between summer and winter modes and the setting of a basic volume flow, etc. Furthermore, operation, filter changes and any faults are displayed. The operating control unit USB interface is part of the standard configuration. Installation is on a flush-mounted box (not included in delivery).

### TOUCH OPERATING CONTROL UNIT

The operating control unit with a 4.3" colour-touch-display is used to control the ventilation unit. Operation is simple and intuitive. The most important settings and readings are very easy to make. The user-friendly handling provides for automatic or manual setting of the ventilation levels. In Automatic mode, the system is controlled by programmable time programmes, closed-loop humidity or CO<sub>2</sub> controls and works in a fully automated fashion, whereas in manual mode ventilation levels may, for instance, be individually increased (boost ventilation). Further functions are the changeover function between summer and winter operation as well as the setting for the

volume flows. The operating mode, temperatures, a required filter change and possible faults are displayed in plain text. The operating control unit also has an integrated temperature sensor, which can be used as a room temperature sensor when needed. Installation is on a flush-mounted box (not included in delivery).

### Advantages of controlling:

- Easy display of current operating settings
- Individually adjustable air volumes
- Time and weekly programs (TOUCH only)

### CONTROL UNIT DIMENSIONS

Item	Dimensions	Item No.
<b>STANDARD: operating control unit MINI for LG 150/250</b>	w x h x d 80 x 80 x 19 mm	08LGMINI150200
<b>OPTIONAL: operating control unit TOUCH for LG 150/250</b>	w x h x d 110 x 84 x 25 mm	08LG150250TC

### CABLE

Item	Type	Item No.
<b>Cable LG control unit max. installation length 100 m</b>	J-Y(ST)Y 2x2x0,8	40LG040340

### EASY OPERATION WITH THE PICHLER APP

*User-friendly:* the compact ventilation unit can be operated easily with our free smartphone app for Android and iOS, whether you are at home or out and about (Gateway required, details on request).



### REMOTE ACCESS / PICHLER CONNECT

*Operational safety:* Remote access facilitates a prompt response with minimal effort for the Pichler customer service in the event of a malfunction (Gateway required, details on request).





CO<sub>2</sub> sensor



Humidity sensor

Humidity and CO<sub>2</sub> sensor

## Accessories

### SPARE FILTER

will ensure perfect hygiene and air quality given regular replacement, also proper functionality and efficient operation of the equipment.

Item	Item number
 Filter ETA ISO Coarse 70% (extract air)	40LG050240
 Filter ODA ISO ePM2,5 55% (outdoor air, default)	40LG050230
 Filter ODA ISO ePM1 80 % (outdoor air, pollen filter)	40LG050250

### DEMAND-ORIENTED VENTILATION CONTROL

CO<sub>2</sub> and humidity sensors for demand-oriented ventilation control. The ventilation unit will automatically increase or reduce the air volumes depending on the quality of the air in the room. The sensor in the surface-mounted housing is suitable for wall mounting.

*Colour:* white

*Dimensions:* W x H x D = 85 x 85 x 35 mm

*Ambient temperature:* 10-50°C

*Measuring range:* 0-2000 ppm

*Sensor supply voltage:* 24V AC/DC

*Control signal:* 0-10 V

Item	Item number
CO <sub>2</sub> sensor	07RC0248330

*Colour:* white

*Dimensions:* W x H x D = 85 x 85 x 35 mm

*Ambient temperature:* 0-60° C (no condensation)

*Measuring range:* 0-100% RH

*Sensor supply voltage:* 24V AC/DC

*Control signal:* 0-10 V

Item	Item number
Humidity sensor	07RHF49360

Demand-oriented plant operation via CO<sub>2</sub> and/or humidity control is only possible in Automatic mode and must be activated via the PC software.

Assignment of the ventilation levels, the ppm and humidity values can be changed using the PC software.

*The following combinations of sensors can be used:*

- Max 2 x CO<sub>2</sub> sensors
- Max 2 x RH% sensors
- 1 x CO<sub>2</sub> sensor & 1 x RH% sensor

### HUMIDITY AND CO<sub>2</sub> SENSOR

Humidity and CO<sub>2</sub> sensor, suitable for surface or flush mounting, for on-demand control of the volume flow, configuration adjustable via DIP switches.

*Material housing:* plastic ABS similar to RAL 9010

*Dimensions:* W x H x D = 80 x 105 x 24 mm

*Protection class:* IP 30 according to IEC 529

*Power supply:* 24 V AC/DC

*Humidity measurement range:* 0 - 100 % RH

*Measurement accuracy:* ± 3% (from 20-80% RH)

*Output signal:* 0-10V

*Carbon dioxide sensor:* optical sensor (NOIR)

*Measuring range CO<sub>2</sub>:* 0 - 2000 ppm

*Measuring accuracy:* ± 30 ppm / ± 5 % of measured value

*Output signal:* 0-10V/ OC 24V 50mA

Item	Item number
Humidity and CO <sub>2</sub> sensor	07RC02TRH

### FLEXIBLE CONNECTION

Made of laminated and highly tear-resistant fabric and with double-sided sleeves made of galvanized sheet steel. With diameter: 125 mm, socket size, elongated length 150 mm.

Item	Item number
flexible connection	01STR0125

### WALL ENDING

Serves to provide for the thermal bridge-free insulation of outdoor air and exhaust air ducts towards the wall. Self-adhesive.

Item	Dimensions W x H x D	Item number
Wall ending	675 x 160 x 22 mm	08LG150WA15

### DEVICE SIPHON

Serves to provide for the hygienic, proper and spatial separation of the condensate inlet in the on-site siphon.

Item	Item number
Device siphon	40LG030620
PVC screw joint: ½ inch to 1 ¼ inch	08REDPVC11412
Connector HL40.2 for HT pipe ø 40 mm, made from PE	08UEGSHL40R12PE
Connector HL30.2 for HT pipe ø 32 mm, made from PE	08UEGSHL30R12PE



MODBUS/KNX-Gateway



MODBUS/NABTO-Gateway



External supply air temperature sensor

### MODBUS/KNX GATEWAY

The Modbus/KNX gateway allows for the connection of the compact ventilation unit LG 150 to a KNX bus system. In this process, the gateway serves as a connective link between the two bus systems. It is provided with a Modbus RTU and TCP interface and is always the master on the Modbus. On the KNX side, however, it responds like a common KNX TP-1 unit. This makes it possible to centrally control and monitor the ventilation unit by a KNX system. The configuration is implemented via the IP or USB interface.

*Dimensions:* W x H x L = 88 x 56 x 90 mm

*Mounting:* Top hat rail or wall

*Permissible ambient temperature:* 0 – 60 °C

*Permissible humidity:* 5 – 95% non-condensing

*Protection class:* IP20

*Voltage:* 24V AC/DC

*Interfaces:* Ethernet, EIA-485, KNX-TP1

Item	Item number
MODBUS/KNX-Gateway	08KNXGA150250A

### MODBUS/NABTO-GATEWAY

Serves to connect the compact ventilation unit with the Internet and furthermore with the Pichler app. When using the gateway the Modbus RTU connection of the building control system is dispensed with.

Item	Item number
MODBUS/NABTO-Gateway	08GATEWAYNABTO

### EXTERNAL SUPPLY AIR TEMPERATURE SENSOR

NTC sensor with metal sleeve.

Item	Item number
NTC sensor, length 2 m	40LG041920

### HOT WATER RE-HEATER BATTERY

Hot water reheater battery for supply air reheating, for pipe installation,  $\varnothing$  125 mm, with accessories.

Only in connection with the external supply air temperature sensor (item number: 40LG041920).

*Air volume:* 180 m<sup>3</sup>/h

*Medium:* 60/40 °C

*Output:* ca. 700 W

*Pipe diameter:*  $\varnothing$  125 mm

*Dimensions:* W x H x D = 238 x 180 x 276

Item	Item number
Hot water re-heater battery	01VBC125

### ELECTRICAL PTC REHEATER FOR SUPPLY AIR REHEATING

Housing of galvanised steel, connections with lip seal. For reheating the supply air for pipe installation  $\varnothing$  125 mm. Only in connection with a temperature sensor (item number: 40LG041920).

*Power:* 900 W with Solid State Relay (SSR)

*Protection class:* IP44

*Pipe diameter:*  $\varnothing$  125 mm

*Dimensions:* W x H x D = 150 x 196 x 276 mm

Item	Item number
Electrical PTC reheater for supply air reheating	08GEPTC125A

### 3-WAY MOTOR CONTROL VALVE

Three-way control ball valve for the continuous closed-loop control of cold and warm water with a mounted closed-loop control actuator.

*Belimo drive:* TR 230-3

*Drive voltage:* 230 V AC

*Control signal:* 3-point

*Control ball valve:* R3015

*Mounting position:* optional

*KVS-Value:* 0,63 m<sup>3</sup>/h

Item	Item number
3-Way Motor control valve	08MISCHER

### COMPLETE PROGRAM FOR AIR DISTRIBUTION SYSTEMS

We offer a complete program of air distribution systems, such as Komflex (round or oval). Details of our air distribution program can be found in the technical documentation.





EPE bend for outdoor and exhaust air

**EPE BEND FOR OUTDOOR AND EXHAUST AIR**

Flexible, segmented, insulated bend. Low pressure drop due to smooth inner surface. Pliable, non-porous, airtight, extremely light, easy to shorten, easy disassembly for maintenance, prevention of condensate formation, corrosion-free.

Diameter: 125 mm  
 Angle: 90°  
 Material: EPE

Density: 30 kg/m<sup>3</sup>

Classification in accordance with EN 13501: E

Thermal coefficient: 0.048 W/mK (EN 12667)

Temperature range: -30 °C to +60 °C

Wall thickness: 16 mm

Air tightness: D (EN 12237) = ATC 2 (EN 16798)

Zeta: 0.88

Item	Item number
Expanded polyethylene (EPE) bend for outdoor air and exhaust air	08EPEB1259016L

**Sound reduction unit**

Compact sound reduction unit for direct mounting to the comfort ventilation unit with efficient especially acoustically shaped diversion splitters installed, galvanised steel sheet outer housing, powder-coated in RAL 9003. The inner part is designed as diversion chamber with acoustically and flow optimized splitters. The splitters are non combustible and

consist of high-strength, wearresistant and moisture repellent glass silk surface. With absorption elements and resonance elements for optimal sound reduction. Adapter with SYSTEM SAFE plug-in fitting. The connections are closed with dust protection caps. With fastening clips for simple wall-mounted or ceilingmounted installation.

**Technical specifications**

**PRESSURE DROP OF THE SOUND REDUCTION UNIT DEPENDING ON THE VOLUME FLOW**

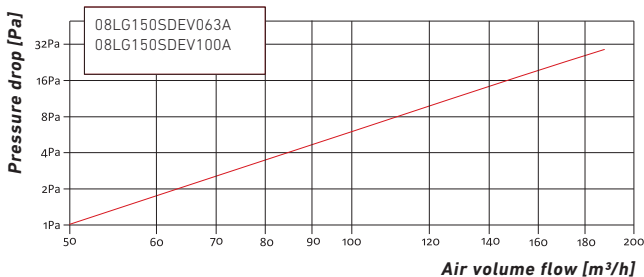

**INSERTION DAMPING OF THE SOUND REDUCTION UNIT**

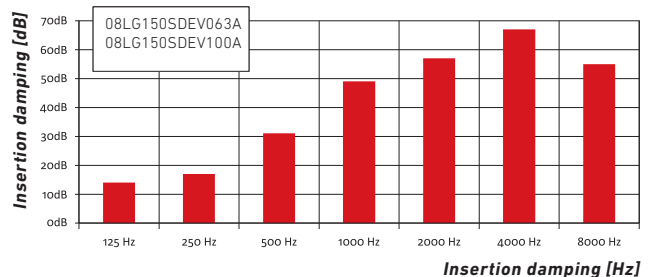

Item	Item number
Sound reduction unit for wall-mounted or ceiling-mounted installation Dimensions (W x H x D) 680 x 795 x 273 mm with 6 connectors ø 100 mm	08LG150SDEV100A
Sound reduction unit for wall-mounted or ceiling-mounted installation Dimensions (W x H x D) 680 x 795 x 273 mm with 12 connectors ø 63 mm for system Komplex	08LG150SDEV063A



**Layout sketch sound reduction unit with 6 connections Ø 100, (wall-mounted or ceiling-mounted installation)**

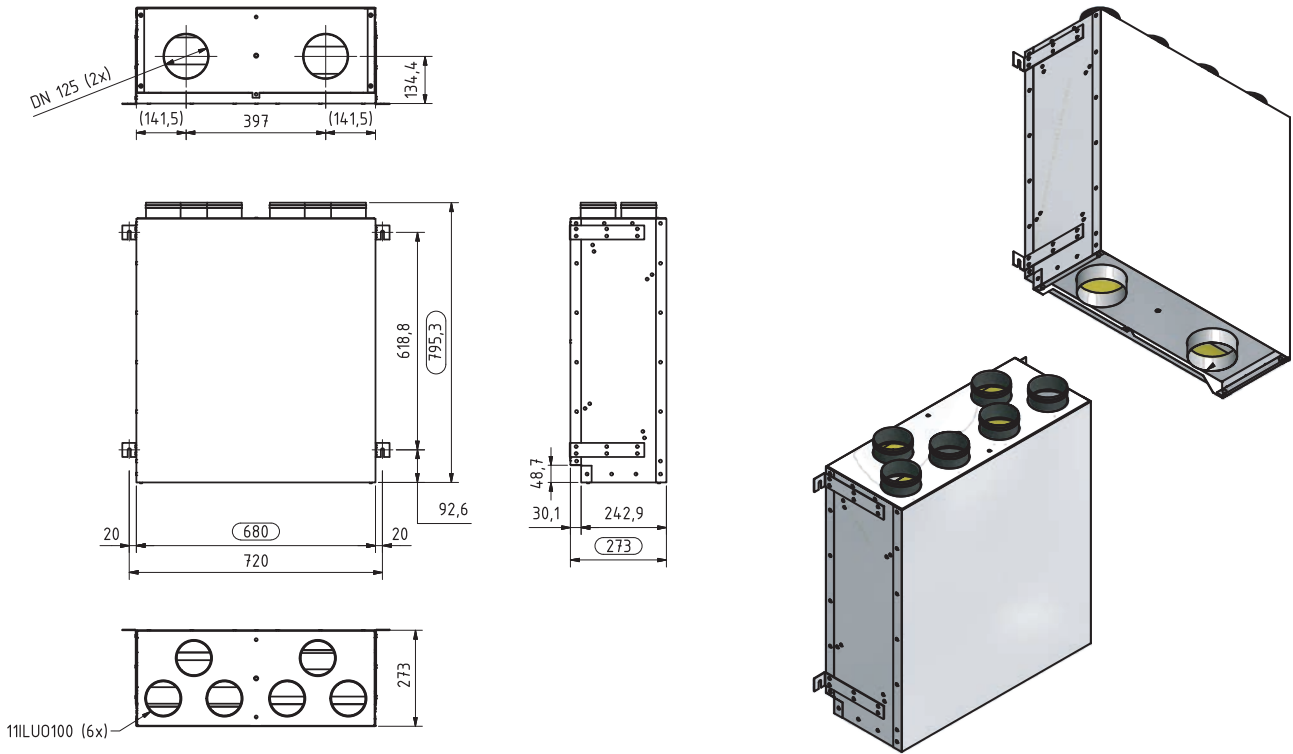

**Layout sketch sound reduction unit with 12 connections Ø 63 for system Komflex 75 mm, (wall-mounted or ceiling-mounted installation)**

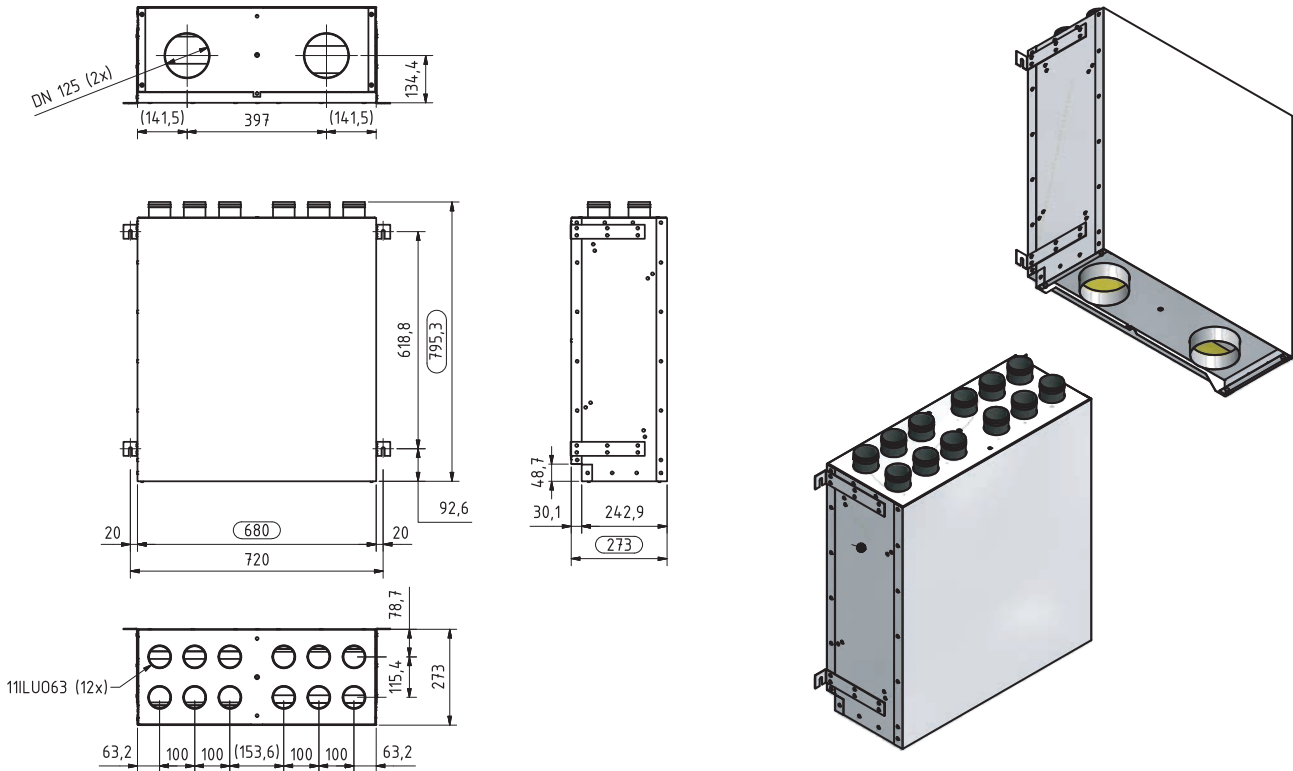

## Cover element

Used for optical veneering of the air line connectors of the comfort ventilation unit towards the wall or the ceiling.

Including 2 guide rails. Dimensionally stable construction of the cover made from galvanized steel, powder-coated in RAL 9003.

Item	Item number
Cover element for LG 150 Dimensions (W x H x D) 680 x 265 x 273 mm As bezel around the external and outdoor air connection of the ventilation unit, facing the wall. Powder-coated in RAL 9003. Including 2 guide rails.	08LG150ABDE265A
Cover element for LG 150 Dimensions (W x H x D) 680 x 80 x 273 mm As bezel around the supply and extract air connection of the ventilation unit, facing the wall or the ceiling. Powder-coated in RAL 9003. Including 2 guide rails.	08LG150ABDE080A

## Layout sketch (wall-mounted installation)

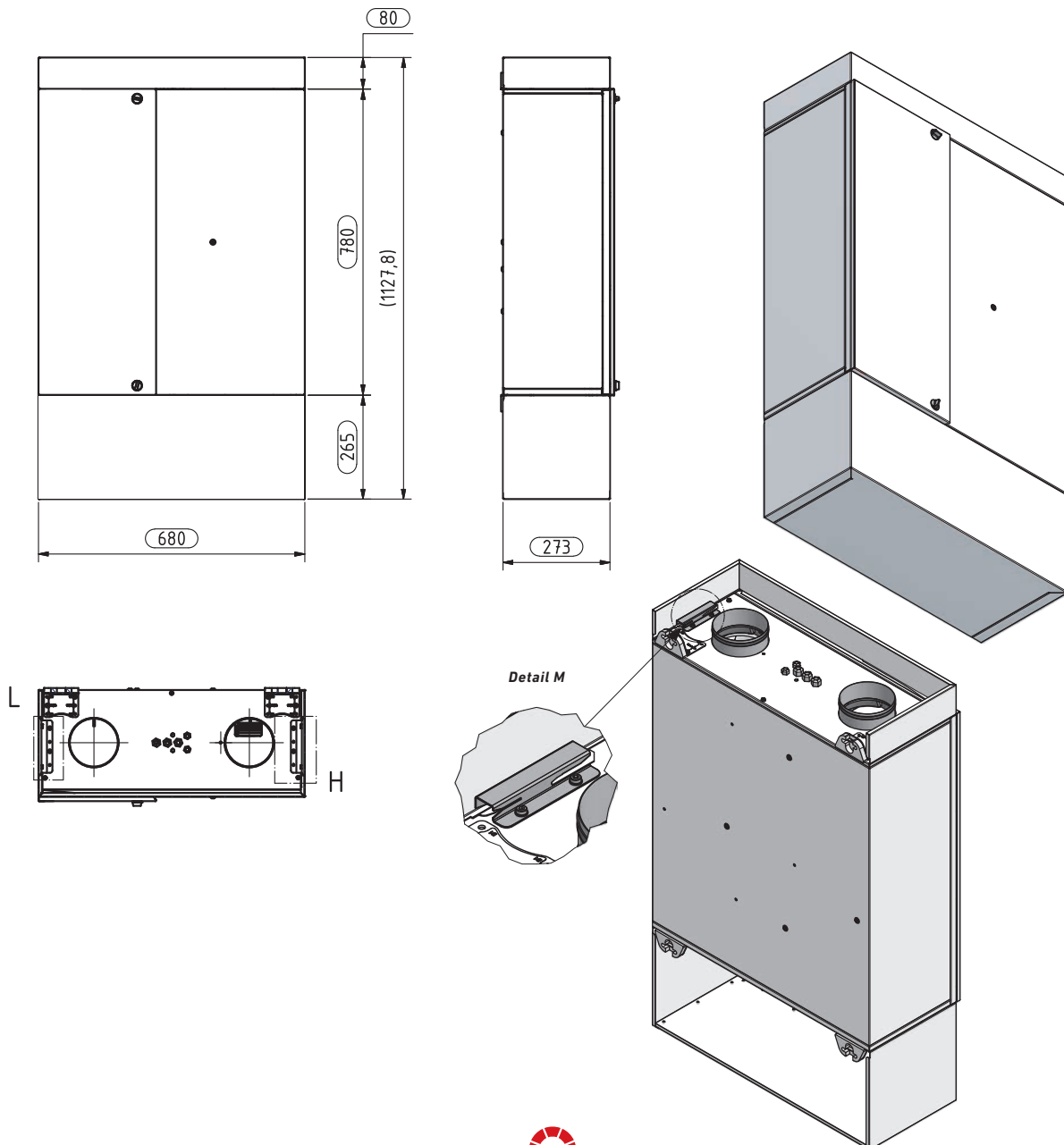

## Flush-mounted set (ceiling-mounted installation)

The flush-mounted set is integrated flush into the suspended/intermediate ceiling, the inspection front of the ceiling providing for the maintenance-friendly access to the ventilation unit installed above. This provides for full panelling of the LG 150 compact ventilation unit incl. the air ducts by a suspended/intermediate ceiling.

**The kit consists of:**

a pre-assembled frame incl. door leaf.  
Fitting material for connecting the flush-mounted set to the concrete ceiling is not included in the scope of supply.

**Material:** sheet steel, galvanised

**Colour:** powder-coated in RAL 9003

**Dimensions:** W x H x D = 836 x 1108 x 76 mm

**Dimensions of the ceiling recess:** W x H = approx. 790 x 1065 mm

Item	Item number
Flush-mounted set for LG 150 In order to provide the whole comfort ventilation unit, including the air connection parts, with panelling behind the drywall. Powder-coated in RAL 9003.	08LG100150REVDE

## Layout sketch (ceiling-mounted installation)

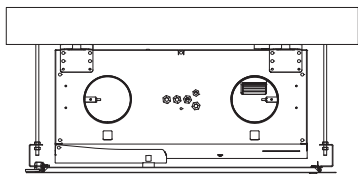
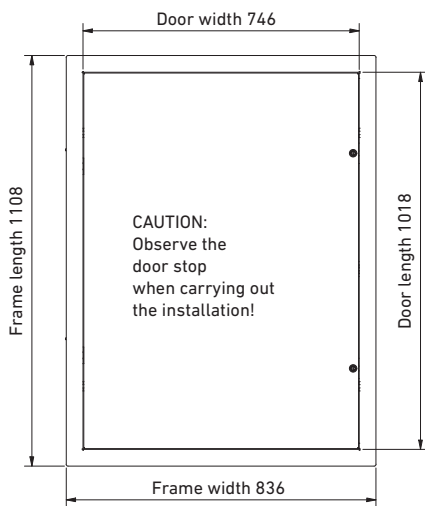

View from below without door

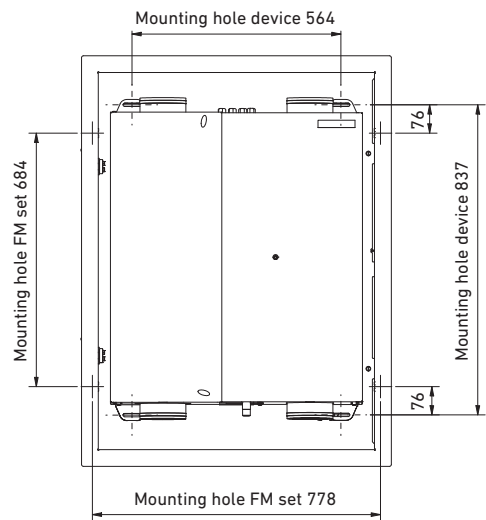

At least 345  
(Raw ceiling – outer surface of suspended ceiling)

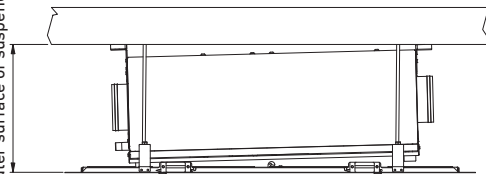

### Flush-mounted set (for Huter frame)

*Flush-mounted set suitable for Huter frame:*  
 ASM WC/Wr.Lü.Pichlerluft (not included in the scope of supply).  
 Provides for full facing of the compact ventilation unit LG 150 including air ducts in the rear wall of the toilet above the cistern. The inspection front allows for maintenance-friendly access to the device.

*Material:* sheet steel, galvanised  
*Colour:* powder-coated in RAL 9003  
*Dimensions:* W x H x D = 889 x 1108 x 100 mm

*Required room heights:*  
*Shell ceiling height:* 2700 mm  
*Finished room height:* 2500 mm  
*Room height with suspended ceiling:* 2345 mm

Item	Item number
Flush-mounted set for Huter frame	08LG150UPSETHUA

The availability of the required Huter frame (item designation: ASM WC/Wr.Lü. Pichlerluft) has to be checked at a regional or country-specific level.

### Layout sketch (flush-mounted set with Huter frame)

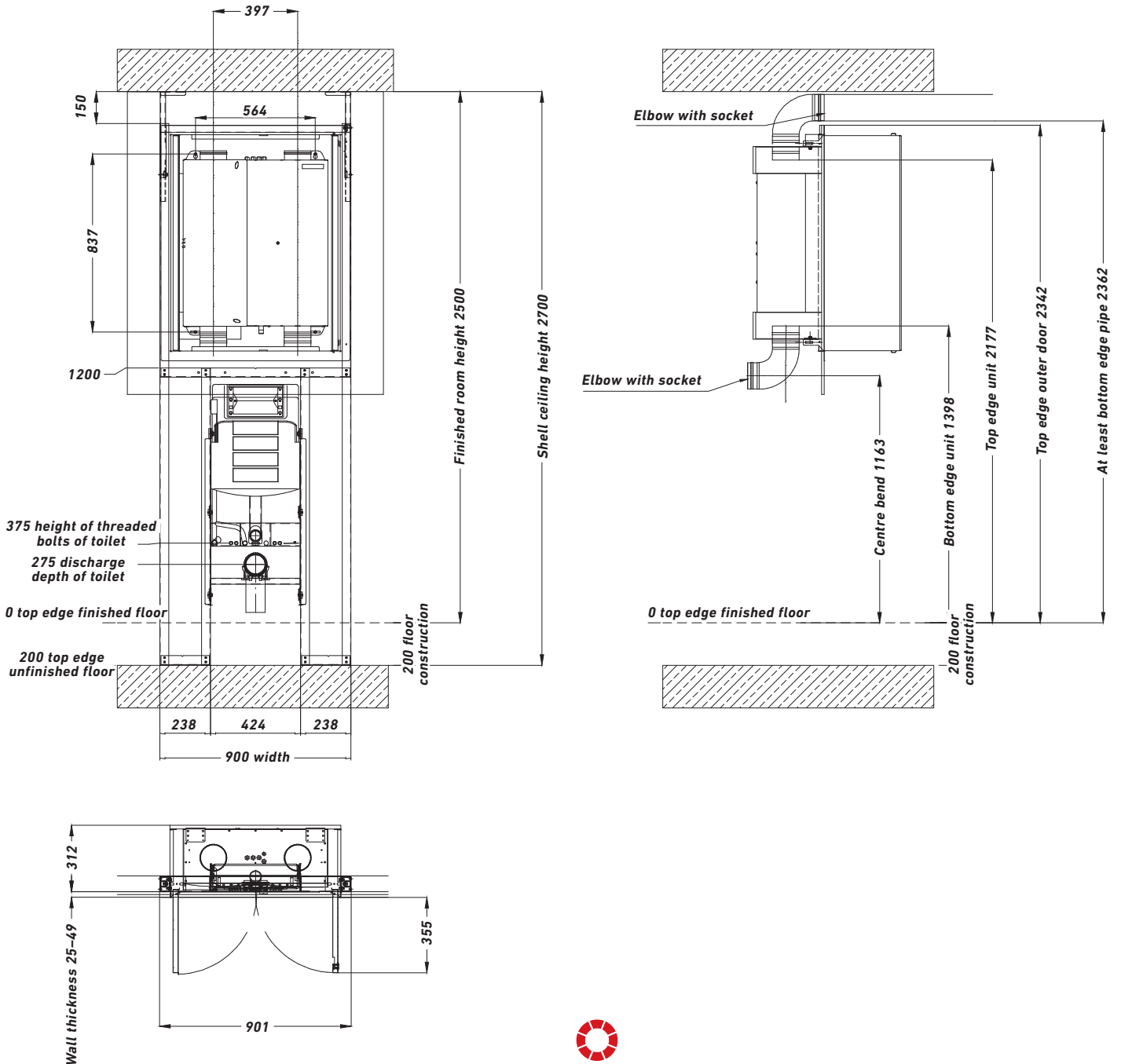

## Mounting examples

### WALL-MOUNTED INSTALLATION IN A TERRACED HOUSE – BASEMENT

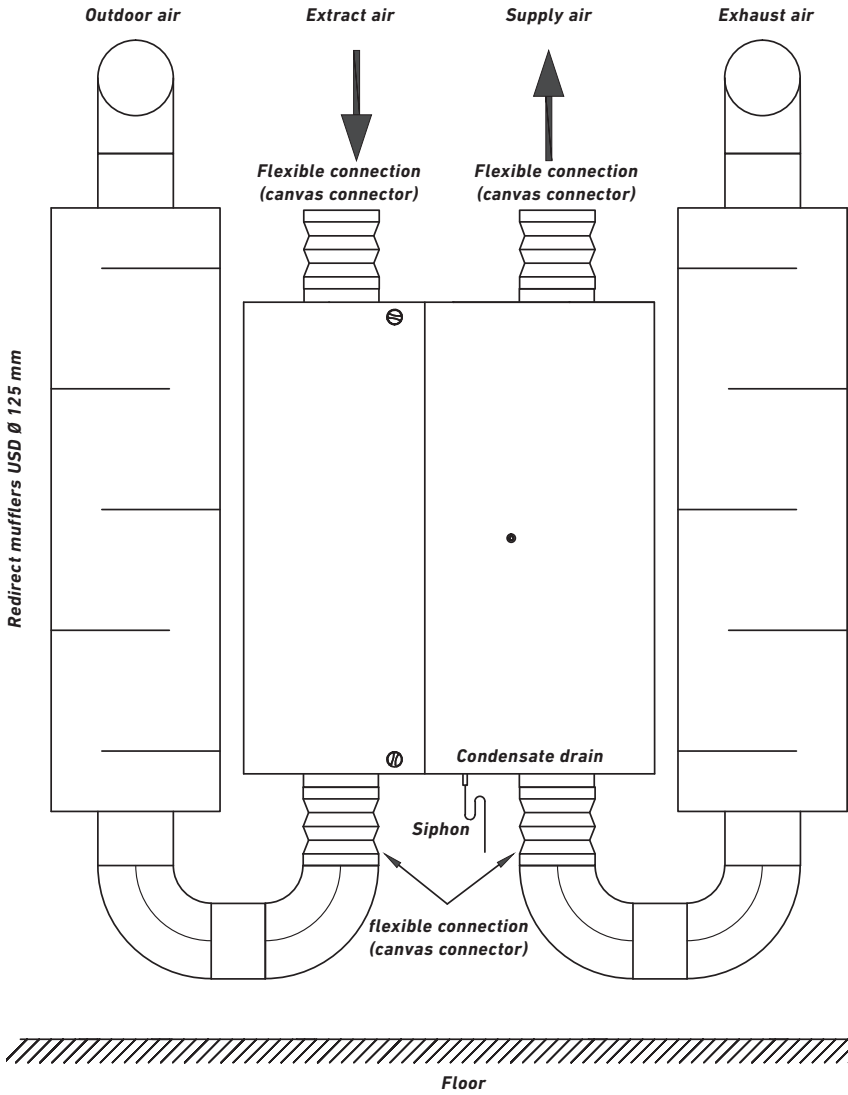

#### DETAIL CONDENSATE CONNECTION WALL

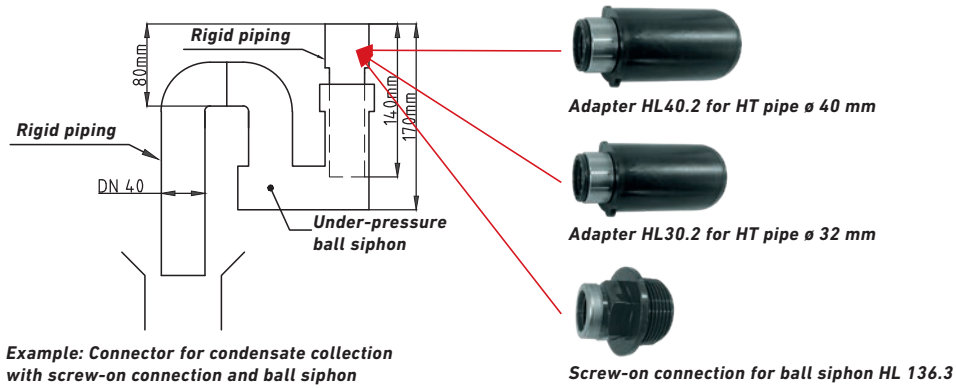



WALL-MOUNTED INSTALLATION WITH A COVER ELEMENT ABOVE THE TOILET TANK IN MULTI-STORY BUILDINGS

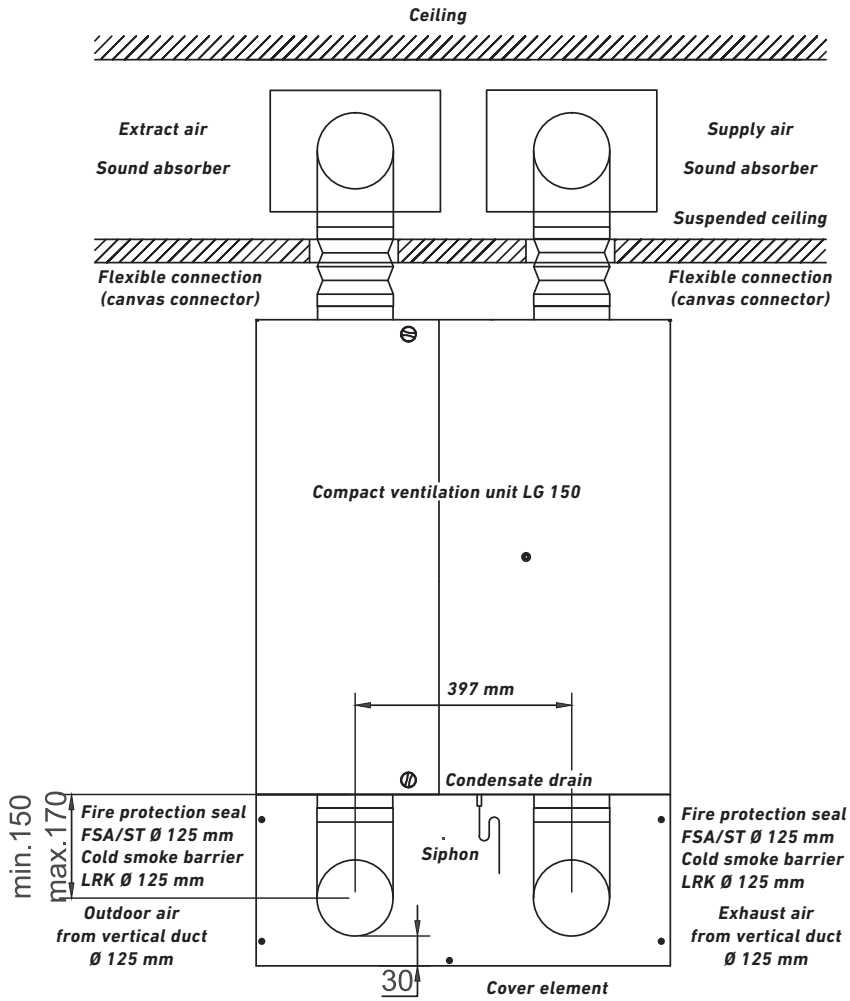

DETAIL CONDENSATE CONNECTION WALL SEE PAGE 19



WALL-MOUNTED INSTALLATION WITH A SOUND INSTALLATION UNIT IN THE STORAGE ROOM IN MULTI-STORY BUILDINGS

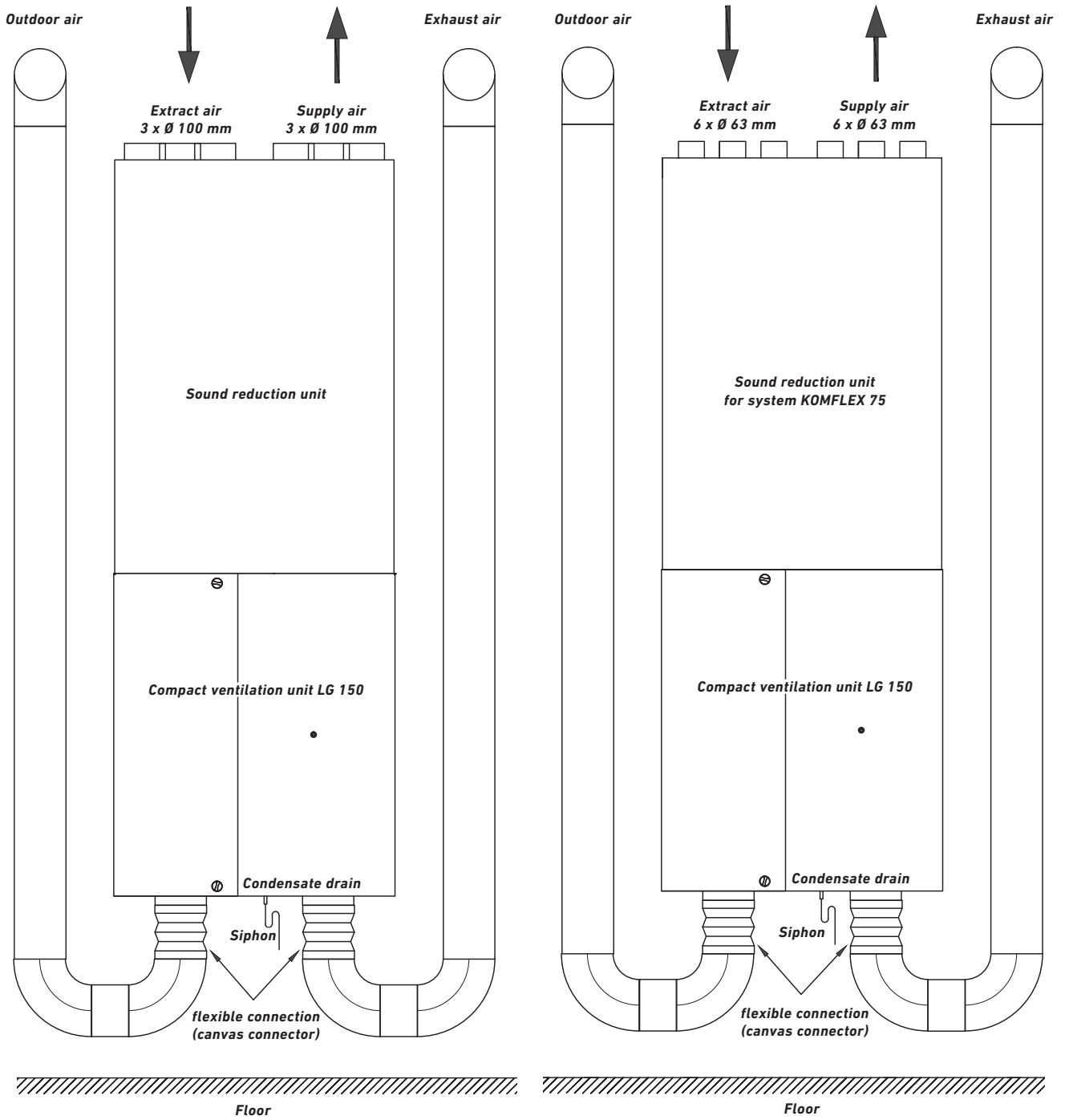

DETAIL CONDENSATE CONNECTION WALL SEE PAGE 19



CEILING-MOUNTED INSTALLATION IN THE STORAGE ROOM/TOILET IN MULTI-STORY BUILDINGS

Exhaust air standpipe  
Outdoor air standpipe

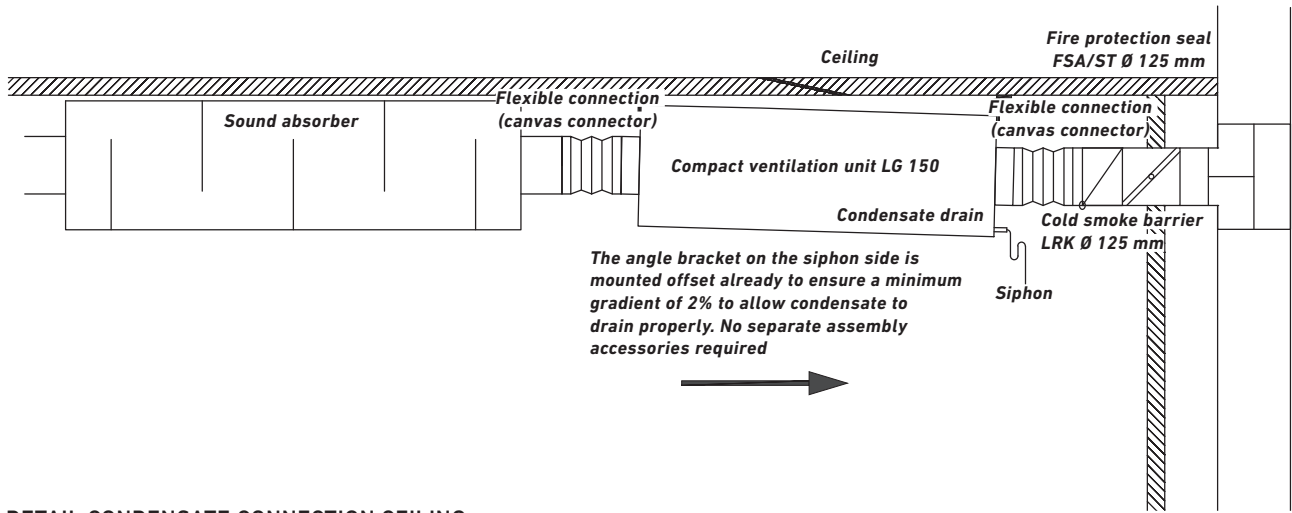

DETAIL CONDENSATE CONNECTION CEILING

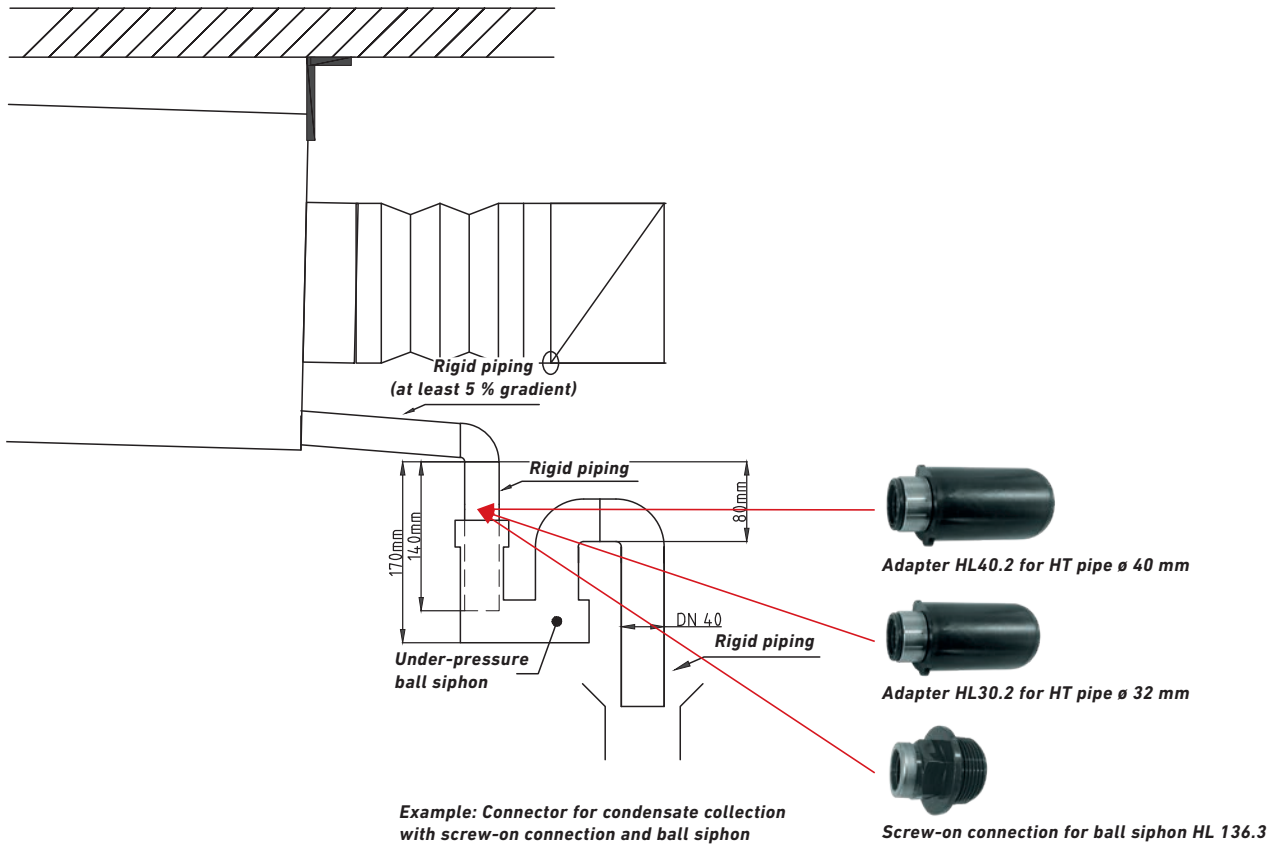

## Data in accordance with EU Regulations 1253/1254-2014

The Pichler ventilation unit meets the requirements of the Eco-design Directive, in accordance with the EU Regulations 1253/1254-2014, and is based on the current state of knowledge (07/07/2014).

### LG 150 A/AF

**Specific energy consumption:**

- A+ is applicable when controlled to local requirements.
- A is applicable when controlled with a manual control, a clock control or a central demand control.

**Maximum air volume flow:** 150 m<sup>3</sup>/h

The specified energy efficiency is applicable when controlled to local requirements and is valid up to the specified maximum air volume flow.

**Sound power level LWA at the reference volume flow:** 39 db(A)

### LG 150 B

**Specific energy consumption:**

- A+ is applicable when controlled to local requirements.
- A is applicable when controlled with a manual control, clock control or a central demand control

**Maximum air volume flow:** 180 m<sup>3</sup>/h

The specified energy efficiency is applicable when controlled to local requirements and is valid up to the specified maximum air volume flow.

**Sound power level LWA at the reference volume flow:** 45 db(A)

### LG 150 BF

**Specific energy consumption:**

- A is applicable when controlled with a central demand control or when controlled to local requirements.
- B is applicable when controlled with a manual control or a clock control.

**Maximum air volume flow:** 180 m<sup>3</sup>/h

The specified energy efficiency is applicable when controlled to local requirements and is valid up to the specified maximum air volume flow.

**Sound power level LWA at the reference volume flow:** 45 db(A)

Download the product fiches on [www.pichlerluft.at](http://www.pichlerluft.at)



## Overview energy efficiency classes

Air control options	manual control			clock control			central demand control			local demand control		
	A/AF	B	BF	A/AF	B	BF	A/AF	B	BF	A/AF	B	BF
ventilation unit LG 150												
LG + operating control unit MINI	A	A	B	-	-	-	-	-	-	-	-	-
LG + operating control unit MINI + 1 x CO <sub>2</sub> sensor*	-	-	-	-	-	-	A	A	A	-	-	-
LG + operating control unit MINI + 1 x RH sensor*	-	-	-	-	-	-	A	A	A	-	-	-
LG + operating control unit MINI + 2 x CO <sub>2</sub> sensor*	-	-	-	-	-	-	-	-	-	A+	A+	A
LG + operating control unit MINI + 2 x RH sensor*	-	-	-	-	-	-	-	-	-	A+	A+	A
LG + operating control unit MINI + 1 x CO <sub>2</sub> + 1 x RH sensor*	-	-	-	-	-	-	-	-	-	A+	A+	A
LG + operating control unit TOUCH	-	-	-	A	A	B	-	-	-	-	-	-
LG + operating control unit TOUCH + 1 x CO <sub>2</sub> sensor*	-	-	-	-	-	-	A	A	A	-	-	-
LG + operating control unit TOUCH + 1 x RH sensor*	-	-	-	-	-	-	A	A	A	-	-	-
LG + operating control unit TOUCH + 2 x CO <sub>2</sub> sensor*	-	-	-	-	-	-	-	-	-	A+	A+	A
LG + operating control unit TOUCH + 2 x RH sensor*	-	-	-	-	-	-	-	-	-	A+	A+	A
LG + operating control unit TOUCH + 1 x CO <sub>2</sub> + 1 x RH sensor*	-	-	-	-	-	-	-	-	-	A+	A+	A

\*see page 10, optional accessories for needs-based operation



## The LG 150 at a glance!

### **Fans:**

Energy-saving radial fans with DC technology (state-of-the-art EC motor technology) with automatic constant volume flow control

### **Counterflow heat exchanger:**

Highly efficient heat recovery system with an air/air counterflow heat exchanger made of recyclable plastic with an automatic 100% bypass

### **Air volume flow:**

LG 150 A of 30 to 150 m<sup>3</sup>/h

LG 150 B of 30 to 200 m<sup>3</sup>/h

with an external pressure of 50 to 250 Pa

### **PTC electrical preheater battery:**

Optionally available as an internal version

### **PTC electrical reheater battery:**

Optionally available as an external version

### **Filters:**

Filter ODA ISO ePM2,5 55% in the outdoor air, filter ETA ISO Coarse 70% in the extract air

### **Housing:**

EPP-housing with equipment cladding, powdercoated in RAL 9003

### **Air connections:**

Left and right-hand versions of the unit. ODA/EHA/SUP/ETA: each Ø 125 mm with a double lip seal

### **Installation position:**

Wall-mounted installation (covering ODA/EHA). Ceiling-mounted installation (in final installation min. 2 % inclined assembled)

### **Summer changeover:**

Integrated 100% bypass flap with seal

### **Service – maintenance – initial startup**

### **OUR COMPACT VENTILATION UNIT LG 150 A/AF HAS BEEN CERTIFIED BY**

- Passivhausinstitut (Passive House Institute) Darmstadt

### **OUR COMPACT VENTILATION UNIT LG 150 A/AF HAS BEEN APPROVED BY**

- DIBt – Deutsches Institut für Bautechnik

### **OUR COMPACT VENTILATION UNIT LG 150 A/AF HAS BEEN TYPE TESTED BY**

- TÜV-AUSTRIA Services GmbH, Testing, Inspection and Certification Centre/Vienna

### **Notice:**

Our product range includes units with a size up to 10,000 m<sup>3</sup>/h as well as comprehensive accessories.



## Notes



## Notes



**ErP 2018**

Fulfills the requirements of the Ecodesign Directive,  
in accordance with EU Regulation 1253/2014.



Your partner/installer:

Responsible for the content: J. Pichler Gesellschaft m.b.H. | Graphics and layout: WERK1  
Photos: Ferdinand Neumüller, J. Pichler Gesellschaft m.b.H. | Text: J. Pichler Gesellschaft m.b.H.  
All rights reserved | All photos are symbolic photos | Subject to change without notice | Version: 12/2022 en/p

**PICHLER**  
Systematic ventilation.

**J. PICHLER**  
Gesellschaft m.b.H.  
office@pichlerluft.at  
www.pichlerluft.at

**AUSTRIA**  
9021 KLAGENFURT  
AM WÖRTHERSEE  
Karlweg 5  
T +43 (0)463 32769  
F +43 (0)463 37548

**AUSTRIA**  
1100 WIEN  
Doerenkampgasse 5  
T +43 (0)1 6880988  
F +43 (0)1 6880988-13

Sales offices in Germany,  
Slovenia, Serbia and  
Bosnia. Sales partners  
in Europe.