



cata 





VENTILATION 2013

# CATA WORLDWIDE

## In over 80 countries

Manufacturer of extractor fans, Cata was founded in Torelló in 1947. Since then, it has been a pioneer in extraction.

Its extensive product catalogue includes the most complete and innovative range of Domestic and Professional Extraction, as well as hand Dryers, Summer Ventilation and Electrical Heating.



Based in Torelló, in the province of Barcelona, Cata also owns factories in Sao Paulo (Brazil) and Xiao Lan (China) and is in constant international expansion thanks to its team of professionals committed to the manufacture and marketing of an extensive range of products.

Cata has reached its position as leader in the extraction market thanks to its great capacity to innovate and its ability to anticipate market needs. Over recent years, it has undergone significant growth in both the Spanish and international markets, based on excellent quality and a high degree of competitiveness in all its products.

Cata's commitment to quality has been borne out by the highest certification, ISO 9001, awarded by the Bureau Veritas Quality International and accredited by the Dutch Council for Accreditation. These international standards ensure a maximum level of quality in the design and manufacture of all products. Likewise, Cata products respond to technical and safety regulations and have been obtained the European approvals of the C. C. A. (Cenelec Certificate Agreement). As a result, Cata is currently one of the leading extraction companies in the world.

# COMPREHENSIVE VENTILATION SOLUTIONS

## WHAT WE OFFER

Integral ventilation solutions. Reliability, Quality, Innovation and Design. Proven experience in ventilation. International industrial capacity. Global service. And most importantly to our customers: **BENEFITS AND ADVANTAGES**

## COMPREHENSIVE VENTILATION SOLUTIONS:

**CATA** provides subscribers, wholesalers and professionals from the sector an extensive product range, which will allow them to choose the most suitable model for every ventilation case or need, at both domestic and industrial level, and now also **models and ranges to comply with the Technical Building Code (CTE), in accordance with Royal Decree 314/2006, dated 17th March 2006.**

## RELIABILITY, QUALITY, INNOVATION AND DESIGN

These concepts are basic and mandatory for **CATA** and are the main reason for all our products. For this reason, a qualified team of engineers assisted by the most modern design systems work to ensure the highest levels of quality, and of innovation, to offer highly reliable ventilation products manufactured according to the **ISO 9001/2000 standard Management System.**



## PROVEN EXPERIENCE IN VENTILATION

A pioneer in the manufacturing of fans, **CATA** has over 60 years' experience in ventilation, strengthening its position as a world leader thanks to the export of proprietary technology and differentiated products.

## INTERNATIONAL INDUSTRIAL CAPACITY

**CATA** has a very important industrial asset, with several production centres around the world equipped with the most modern technology and machinery to be able to offer efficient and competitive distribution of our products and components.



## GLOBAL SERVICE

**CATA** has a multicultural team with a high level of training and a clear customer care and service orientation. In addition, to offer a better service, we have logistics and distribution centres and subsidiaries around the world.

## AND MOST IMPORTANTLY TO OUR CUSTOMERS: BENEFITS AND ADVANTAGES

These are the main aims that the **CATA Ventilation Division** wishes to offer the distributors, customers and professionals in the sector. For this reason, we work and renew our efforts daily to ensure that these objectives are possible.

**cata** 

AXIAL BATHROOM FANS

E GLASS SERIES. Energy-efficient. Low-noise

E - p.10-11



MATIC SERIES

X-MART Matic - p. 12

B-Matic - p. 13



DESIGN SERIES

X-MART - p. 14

SILENTIS - p. 15



CLASIC SERIES

B-Plus - p. 16

B - p. 17

B-Pir - p. 17



CENTRIFUGAL BATHROOM FANS

CB 100 PLUS - p. 18



CB-250 PLUS - p. 18



IN-LINE DUCT FANS

Professional Series

Duct in line - p. 19



Box in line - p. 20



Axial

MT - p. 21



Kit in Line - p. 21





## WALL FANS

LHV - p. 22

B - p. 23



## KITCHEN EXTRACTION

Professional 750 / 500- p. 24

600 PLUS 2V / GS 600 - p. 25

GS 400M / GS 400 P - p. 25



## DOMESTIC VENTILATION ACCESSORIES

Accessories - p. 26



LHV blind



Glass Fixing Kit



Fixed Grill



Grill on pressure



Backdraught shutter



MT support

## PERFORMANCE CURVES

p. 27 - 31

# AXIAL BATHROOM FANS

## E GLASS Series. Energy-efficient. Low-noise

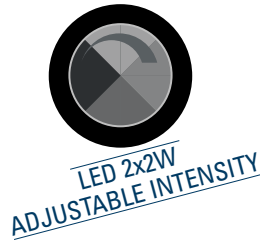

**E-100 GLASS SILVER**



**E-100 GLASS LIGHT**

- Perimeter extraction system.
- Glass cover.
- High-performance plastic housing and impeller.
- Temperature and humidity display (available on humidistat model).
- Backdraught shutter (accessory).
- Fitted with 220-240 50/60Hz motors (110-127V 60Hz on request), IP-44 protection and insulation class B as standard.
- 2-speed function (humidistat version only), > 1st speed: to be selected prior to installation between continuous or NON continuous working.  
> 2nd speed: activates when light is switched on, by activating the humidistat or the timer.

### REMOVABLE GLASS FRONT



#### EASILY REMOVABLE

Easy and speedy removal of the cover using a single tool (included in the packaging) which is also used to adjust the timer (GT and GTH version) and the humidistat (GTH version).

#### EASY TO CLEAN

Extra-flat white glass cover that is easy to clean just by running a damp cloth over it.

E-100 G  
E-120 G  
E-150 G  
E-100 GT  
E-120 GT  
E-150 GT



E-100 GS  
E-100 GST  
E-100 GSH

E-100 GTH  
E-120 GTH  
E-150 GTH



E-100 GL  
E-100 GLS

CODE	MODEL	EAN CODE	VERSION	Ø (mm)	Voltage (V)	Speed (r.p.m)	Input Power (W)	Maximum Airflow (m³/h)	Sound Pressure Level dB(A)	Units per box
<b>HYGRO SERIES</b>										
00900200	E-100 GTH	8422248049634	●	100	220-240	1ª vel 1100 2ª vel 2600	4 8	36 115	17 31	6
00900600	E-100 GSH	8422248056076	●	100	220-240	1ª vel 1100 2ª vel 2600	4 8	36 115	17 31	6
00901200	E-120 GTH	8422248056823	●	120	220-240	2400	15	210	33	6
00902200	E-150 GTH	8422248056854	●	150	220-240	2200	21	350	35	6
<b>TIMER SERIES</b>										
00900100	E-100 GT	8422248049627	●	100	220-240	2600	8	115	31	6
00900500	E-100 GST	8422248056069	●	100	220-240	2600	8	115	31	6
00901100	E-120 GT	8422248056816	●	120	220-240	2400	15	210	33	6
00902100	E-150 GT	8422248056847	●	150	220-240	2200	21	350	35	6
<b>STANDAR SERIES</b>										
00900000	E-100 G	8422248049610	●	100	220-240	2600	8	115	31	6
00900400	E-100 GS	8422248056052	●	100	220-240	2600	8	115	31	6
00900001	E-100 GL	8422248056786	●	100	220-240	2600	8+4	115	31	6
00900401	E-100 GLS	8422248056793	●	100	220-240	2600	8+4	115	31	6
00901000	E-120 G	8422248056809	●	120	220-240	2400	15	210	33	6
00902000	E-150 G	8422248056830	●	150	220-240	2200	21	350	35	6

#### DIMENSIONS mm

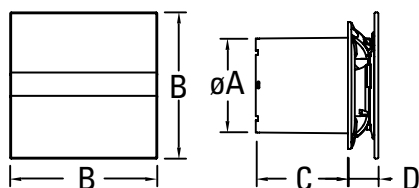

	Ø A	B	C	D
E GLASS -100	98	150	94	28,5
E GLASS -120	118	170	94	35
E GLASS -150	148	190	94	45
E GLASS -100 LIGHT	98	150	94	35

#### Versions



**STANDARD**  
In combination with light, fans switches on.



**TIMER**  
Electronic timer adjustable from 3 to 15 minutes.



**HYGRO**  
Adjustable humidity detector from 40% to 95%, and adjustable electronic timer from 0 seconds to 15 minutes.

Perimetral bathroom fans, with unique automatic shutter system.

## X-MART MATIC / X-MART MATIC INOX



- Automatic shutter system.
- Recessed and design of a new generation.
- **QUICK FIX GRIP**, exclusive mounting system
- Front cover easy to dismantle without using any tools, easy cleaning.
- 220-240V 50/60Hz motors, protection **IP-X4** insulation class **B** and thermal cut out, ambient temperature max. 40°C.
- Plastic housing, impeller and led.
- Finishes: White / Stainless Steel.



CODE	MODEL	EAN CODE	VERSION	Ø (mm)	Voltage (V)	Speed (r.p.m)	Input Power (W)	Maximum AirFlow (m³/h)	Sound Pressure Level dB(A)	Weight (kg)	Units per box
<b>HYGRO SERIES</b>											
01047000	X-MART 10 MATIC INOX H	8422248003742	●	100	230	2500	15	98	38	0,78	5
01057000	X-MART 12 MATIC INOX H	8422248003773	●	120	230	2450	20	190	40	0,98	5
01067000	X-MART 15 MATIC INOX H	8422248003803	●	150	230	2100	25	320	42	1,14	5
<b>TIMER SERIES</b>											
01016000	X-MART 10 MATIC T	8422248003551	●	100	230	2500	15	98	38	0,65	10
01026000	X-MART 12 MATIC T	8422248003582	●	120	230	2450	20	190	40	0,82	5
01046000	X-MART 10 MATIC INOX T	8422248003735	●	100	230	2500	15	98	38	0,78	10
01056000	X-MART 12 MATIC INOX T	8422248003766	●	120	230	2450	20	190	40	0,98	5
01066000	X-MART 15 MATIC INOX T	8422248003797	●	150	230	2100	25	320	42	1,14	5
<b>STANDAR SERIES</b>											
01015000	X-MART 10 MATIC	8422248003544	●	100	230	2500	15	98	38	0,65	10
01025000	X-MART 12 MATIC	8422248003575	●	120	230	2450	20	190	40	0,82	5
01035000	X-MART 15 MATIC	8422248003605	●	150	230	2100	25	320	42	0,97	5
01045000	X-MART 10 MATIC INOX	8422248003728	●	100	230	2500	15	98	38	0,78	10
01055000	X-MART 12 MATIC INOX	8422248003759	●	120	230	2450	20	190	40	0,98	5
01065000	X-MART 15 MATIC INOX	8422248003780	●	150	230	2100	25	320	42	1,14	5

### DIMENSIONS mm

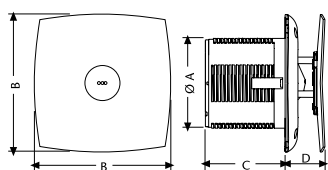

	Ø A	B	C	D
X-MART MATIC 10	98	150	87	38 máx.
X-MART MATIC 12	118	170	101	38 máx.
X-MART MATIC 15	148	194	120	38 máx.

### Versions



**STANDARD**  
In combination with light, fans switches on.



**TIMER**  
Electronic timer adjustable from 3 to 15 minutes.



**HYGRO**  
Adjustable humidity detector from 40% to 90%, and adjustable electronic timer from 0 to 15 minutes.

Axial fans for bathrooms, with short tube, to be installed in ceiling, wall or window.

## B-MATIC

- With automatic shutter.
- White finish.
- Plastic housing and impeller.
- 220-240V 50/60Hz motors, protection **IP-X4**, insulation class **B** and thermal cut out, ambient temperature max. 40°C.
- Neon light sensor in **HUMIDISTAT** and gasket to minimize vibrations.



CODE	MODEL	EAN CODE	VERSION	Ø (mm)	Voltage (V)	Speed (r.p.m)	Input Power (W)	Maximum AirFlow (m³/h)	Sound Pressure Level dB(A)	Weight (kg)	Units per box
<b>SERIE TIMER</b>											
00916000	B-10 MATIC T	8422248110303	●	100	230	2500	15	98	41	0,70	5
00926000	B-12 MATIC T	8422248110808	●	120	230	2450	20	190	43	0,90	5
<b>SERIE ESTANDAR</b>											
00915000	B-10 MATIC	8422248110204	●	100	230	2500	15	98	41	0,70	5
00925000	B-12 MATIC	8422248110709	●	120	230	2450	20	190	43	0,90	5
00935000	B-15 MATIC	8422248111102	●	150	230	2100	28	320	43	1,20	5

### DIMENSIONS mm

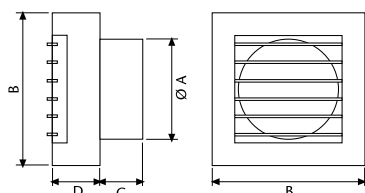

	Ø A	B	C	D
B-10 MATIC	98	150	42	47
B-12 MATIC	118	180	45	56
B-15 MATIC	148	209	60	58

### Versions



**STANDARD**  
In combination with light, fans switches on.



**TIMER**  
Electronic timer adjustable from 3 to 15 minutes.

Perimetral bathroom fans, with unique automatic shutter system.

## X-MART / X-MART INOX



STAINLESS STEEL  
VERSION



- Aerodynamic and cutting-edge design.
- **QUICK FIX GRIP**, exclusive mounting system.
- Backdraught shutters incorporated.
- Front cover easy to dismantle without using any tools, easy cleaning.
- 220-240V 50/60Hz motors, protection **IP-X4** insulation class **B** and thermal cut out, ambient temperature max. 40°C.
- Plastic housing, impeller and led.
- Finishes: White / Stainless Steel.

CODE	MODEL	EAN CODE	VERSION	Ø (mm)	Voltage (V)	Speed (r.p.m)	Input Power (W)	Maximum AirFlow (m³/h)	Sound Pressure Level dB(A)	Weight (kg)	Units per box
<b>HYGRO SERIES</b>											
01044000	X-MART 10 INOX H	8422248003650	●	100	230	2500	15	98	38	0,66	5
01054000	X-MART 12 INOX H	8422248003681	●	120	230	2450	20	190	40	0,87	5
01064000	X-MART 15 INOX H	8422248003711	●	150	230	2100	25	320	42	1,04	5
<b>TIMER SERIES</b>											
01011000	X-MART 10 T	8422248003414	●	100	230	2500	15	98	38	0,64	10
01021000	X-MART 12 T	8422248003438	●	120	230	2450	20	190	40	0,84	5
01041000	X-MART 10 INOX T	8422248003643	●	100	230	2500	15	98	38	0,66	10
01051000	X-MART 12 INOX T	8422248003674	●	120	230	2450	20	190	40	0,87	5
01061000	X-MART 15 INOX T	8422248003704	●	150	230	2100	25	320	42	1,04	5
<b>STANDAR SERIES</b>											
01010000	X-MART 10	8422248003384	●	100	230	2500	15	98	38	0,64	10
01020000	X-MART 12	8422248003391	●	120	230	2450	20	190	40	0,84	5
01030000	X-MART 15	8422248003407	●	150	230	2100	25	320	42	1,02	5
01040000	X-MART 10 INOX	8422248003636	●	100	230	2500	15	98	38	0,66	10
01050000	X-MART 12 INOX	8422248003667	●	120	230	2450	20	190	40	0,87	5
01060000	X-MART 15 INOX	8422248003698	●	150	230	2100	25	320	42	1,04	5

### DIMENSIONS mm

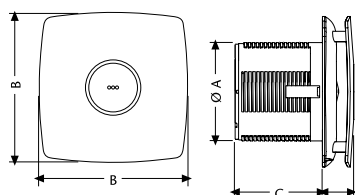

	Ø A	B	C	D
X-MART 10	98	150	89,5	31
X-MART 12	118	170	103,5	32
X-MART 15	148	194	123,5	34

### Versions



**STANDARD**  
In combination with light, fans switches on.



**TIMER**  
Electronic timer adjustable from 3 to 15 minutes.



**HYGRO**  
Adjustable humidity detector from 40% to 90%, and adjustable electronic timer from 0 to 15 minutes.

Completely built-in bathroom fans with perimetral and central extraction system, high-performance and low noise level.

## SILENTIS / SILENTIS INOX



- Cutting-edge design.
- Backdraught shutters incorporated.
- Front cover easy to dismantle and to clean.
- Plastic housing and impeller and led.
- 220-240V 50/60Hz motors, protection IP-X4 insulation class B and thermal cut out, ambient temperature max. 40°C.
- Finishes: White / Stainless Steel.



CODE	MODEL	EAN CODE	VERSION	Ø (mm)	Voltage (V)	Speed (r.p.m)	Input Power (W)	Maximum AirFlow (m³/h)	Sound Pressure Level dB(A)	Weight (kg)	Units per box
<b>SERIE TIMER</b>											
01071000	SILENTIS 10 T	8422248016940	●	100	230	2500	15	98	37	0,64	10
01081000	SILENTIS 12 T	8422248016988	●	120	230	2450	20	190	39	0,85	5
01091000	SILENTIS 15 T	8422248017022	●	150	230	2100	25	320	41	1,02	5
01071300	SILENTIS 10 INOX T	8422248016964	●	100	230	2500	15	98	37	0,64	10
01081300	SILENTIS 12 INOX T	8422248017008	●	120	230	2450	20	190	39	0,85	5
<b>SERIE ESTADAR</b>											
01070000	SILENTIS 10	8422248016643	●	100	230	2500	15	98	37	0,64	10
01080000	SILENTIS 12	8422248016971	●	120	230	2450	20	190	39	0,85	5
01090000	SILENTIS 15	8422248017015	●	150	230	2100	25	320	41	1,02	5
01070300	SILENTIS 10 INOX	8422248016957	●	100	230	2500	15	98	37	0,64	10
01080300	SILENTIS 12 INOX	8422248016995	●	120	230	2450	20	190	39	0,85	5

### DIMENSIONS mm

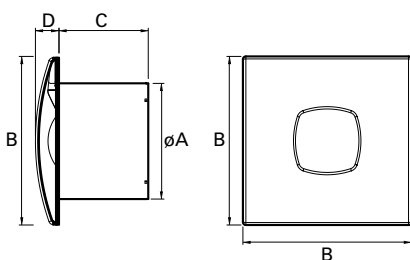

	Ø A	B	C	D
SILENTIS 10	98	140	98	10
SILENTIS 12	118	170	100	13
SILENTIS 15	148	190	112	15

### Versions



**STANDARD**  
In combination with light, fans switches on.



**TIMER**  
Electronic timer adjustable from 3 to 15 minutes.

**Axial fans for bathrooms, very slim, to be installed in ceiling or wall.**

## B-PLUS



- Very slim, recessed design.
- Plastic housing and impeller.
- 220-240V 50/60Hz motors, protection **IP-X4**, insulation class **B** and thermal cut out, ambient temperature max. 40°C.
- Light sensor in **HUMIDISTAT** version and **B15 PLUS** models.
- Window kit not available for models **B8 PLUS** and **B15 PLUS**.



CODE	MODEL	EAN CODE	VERSION	Ø (mm)	Voltage (V)	Speed (r.p.m)	Input Power (W)	Maximum AirFlow (m³/h)	Sound Pressure Level dB(A)	Weight (kg)	Units per box
<b>SERIE HYGRO</b>											
00981401	<b>B10 PLUS H</b>	8422248050876	●	100	230	2500	15	98	41	0,6	10
<b>SERIE TIMER</b>											
00981101	<b>B10 PLUS T</b>	8422248049566	●	100	230	2500	15	98	41	0,6	10
00982100	<b>B12 PLUS T</b>	8422248113489	●	120	230	2450	20	190	43	0,8	5
00983100	<b>B15 PLUS T</b>	8422248114257	●	150	230	2100	28	320	43	0,9	5
<b>SERIE ESTANDAR</b>											
00990000	<b>B8 PLUS</b>	8422248113168	●	90	230	2500	15	70	39	0,57	10
00281000	<b>B10 PLUS</b>	8422248047906	●	100	230	2500	15	98	41	0,6	10
00981201	<b>B10 PLUS C</b>	8422248049573	●	100	230	2500	15	98	41	0,6	10
00982000	<b>B12 PLUS</b>	8422248113472	●	120	230	2450	20	190	43	0,8	5
00983000	<b>B15 PLUS</b>	8422248114226	●	150	230	2100	28	320	43	0,9	5

### DIMENSIONS mm

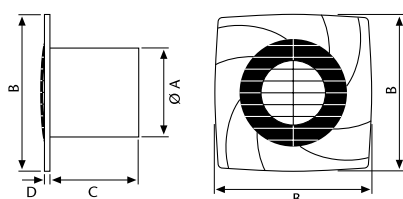

	Ø A	B	C	D
B-8 PLUS	86	140	88	10
B-10 PLUS	98	140	85	10
B-12 PLUS	118	170	100	13
B-15 PLUS	148	190	112	15

### Versions



**STANDARD**  
In combination with light, fans switches on.



**TIMER**  
Electronic timer adjustable from 3 to 15 minutes.



**HYGRO**  
Adjustable humidity detector from 40% to 90%, and adjustable electronic timer from 0 to 15 minutes.



**PULL CORD**  
Cord on-off switch.



## Axial fans for bathrooms with short tube for wall, ceiling and glass (using Glass Kit accessory).

### B



**SHORT  
TUBE**

- White finishing.
- Plastic housing and impeller.
- Fitted with 220-240V 50/60Hz motors, **IP-X4** protection and class **B** as standard.
- Neon light sensor in humidistat versions.

CODE	MODEL	EAN CODE	VERSION	Ø (mm)	Voltage (V)	Speed (r.p.m)	Input Power (W)	Maximum AirFlow (m³/h)	Sound Pressure Level dB(A)	Weight (kg)	Units per box
<b>SERIE TIMER</b>											
00911000	<b>B-10 T</b>	8422248110105	●	100	230	2500	15	98	41	0,60	10
<b>SERIE ESTANDAR</b>											
00910000	<b>B-10</b>	8422248110006	●	100	230	2500	15	98	41	0,60	10
00920000	<b>B-12</b>	8422248110501	●	120	230	2450	20	190	43	0,85	5
00930000	<b>B-15</b>	8422248110907	●	150	230	2100	28	320	43	0,95	5

#### DIMENSIONS mm

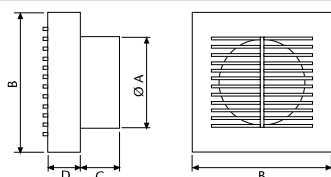

	Ø A	B	C	D
B-10	98	150	42	35
B-12	118	180	45	44
B-15	148	209	60	45

## Axial fans for bathrooms with infra-red sensor.

### B-PIR



**SHORT  
TUBE**

- Fitted with infra-red sensor activated by presence.
- Timer (electronic timer adjustable from 3 to 15 minutes).
- White finishing.
- Plastic housing and impeller.
- 220-240V 50/60Hz motor, protection **IP-X4**, insulation class **B** as thermal cut out, ambient temperature max. 40°C.

CODE	MODEL	EAN CODE	Ø (mm)	Voltage (V)	Speed (r.p.m)	Input Power	Maximum AirFlow (W)	Sound Pressure (m³/h)	Weight (kg)	Units per box
00913000	<b>B-10 PIR</b>	8422248112123	100	230	2500	15	98	41	0,60	4

#### DIMENSIONS mm

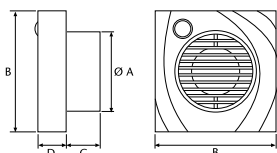

	Ø A	B	C	D
B-10 PIR	98	150	42	35

#### Versions



**STANDARD**  
In combination with light, fans switches on.



**TIMER**  
Electronic timer adjustable from 3 to 15 minutes.

# CENTRIFUGAL BATHROOM FANS

High-performance centrifugal bathroom fans, slim version, to be installed in ceilings or walls.

## CB-100 PLUS / CB-250 PLUS



CB-100 PLUS



CB-250 PLUS

- **CB-100 PLUS** totally recessed.
- Finishing: white.
- **CB-250** with short tube.
- Modern slim version.
- Centrifugal impeller for high pressure, which need to be passed in longer ductings.
- Back-draught shutters included.
- Plastic housing and impeller.
- 220-240V 50/60Hz motors, protection **IP-X4**, insulation class **B** and thermal cut out, ambient temperature max. 40°C.

CODE	MODEL	EAN CODE	VERSION	Ø (mm)	Voltage (V)	Speed (r.p.m)	Input Power (W)	Maximum AirFlow (m³/h)	Sound Pressure Level dB(A)	Weight (kg)	Units per box
<b>SERIE TIMER</b>											
00841000	<b>CB-100 PLUS T</b>	8422248114394	●	100	230	2300	25	130	49	0,98	5
00851000	<b>CB-250 PLUS T</b>	8422248114424	●	100/120	230	2300	45	270	52	1,64	5
<b>SERIE ESTANDAR</b>											
00840000	<b>CB-100 PLUS</b>	8422248114387	●	100	230	2300	25	130	49	0,98	5
00850000	<b>CB-250 PLUS</b>	8422248114417	●	100/120	230	2300	45	270	52	1,64	5

### DIMENSIONS mm

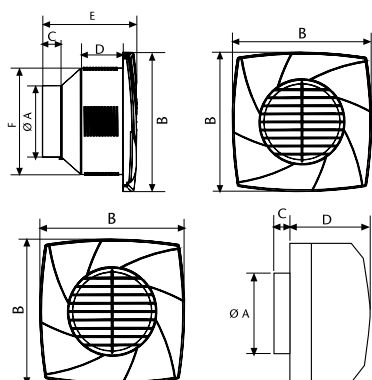

	Ø A	B	C	D	E	F
CB-100 PLUS	97,6	190	26	57,4	129,4	147,8

	Ø A	B	C	D
CB-250 PLUS	96/118	208	17	122

\* Double outflow diameter included.

### Versions



**STANDARD**  
In combination with light, fans switches on.



**TIMER**  
Electronic timer adjustable from 3 to 15 minutes.

# IN-LINE DUCT FANS

In line mixed flow fans with high performance air flow capacity and low noise level.

## DUCT IN-LINE



### Fan:

- Housing polypropylene plastic.
- Easy accessible motor due to the motor support, which can be dismantled without interfering existing duct system. (1)

### Motor:

- Asynchronous 1, 2 and 3 speeds motor, self-lubricating bearings for life.
- Protection **IP44** insulation Class **B** (not **DUCT IN-LINE 100/130**), and thermal cut out.
- External terminal box.
- 230 V at 50 and 60 Hz (**DUCT IN-LINE 100/130**, just in 50 Hz).
- Speed control possible (not timer versions).
- **TIMER** version models adjustable from 3 to 15 minutes.

### Impeller:

- High performance and very silence helicocentrifugal mixed flow, made in ABS plastic.
- **DUCT IN-LINE 100/130** with centrifugal impeller.

### Accessories:

- Electric speed controllers **REGM**.
- Fixed plastic grills.
- Fixed plastic grills with flyscreen.

CODE	MODEL	EAN CODE	Speed (r.p.m)	Input Power (W)	Max. Amps (A)	AirFlow (m³/h)	Sound Pressure Level dB(A)	Weight (kg)
<b>SERIE TIMER</b>								
00771000	DUCT IN-LINE 100/130 T	8422248920742	2.200	25	0,16	130	24	1,2
00702100	DUCT IN-LINE 100/270 T	8422248021210	2.300/1.700	30/18	0,18/0,10	270/190	30/24	2,1
00703100	DUCT IN-LINE 125/320 T	8422248021234	2.300/1.700	30/18	0,18/0,10	365/250	32/26	2,1
<b>SERIE ESTANDAR</b>								
00770000	DUCT IN-LINE 100/130	8422248920735	2.200	25	0,16	130	24	1,2
00702000	DUCT IN-LINE 100/270	8422248021203	2.300/1.700	30/18	0,18/0,10	270/190	30/24	2,1
00703000	DUCT IN-LINE 125/320	8422248021227	2.300/1.700	30/18	0,18/0,10	365/250	32/26	2,1
00704000	DUCT IN-LINE 150/560	8422248021241	2.700/2.000	80/60	0,36/0,27	595/420	33/27	3,2
00705000	DUCT IN-LINE 160/560	8422248021265	2.700/2.000	80/60	0,36/0,27	595/420	33/27	3,2
00706000	DUCT IN-LINE 200/910	8422248021289	2.700/2.000/1.800	85/65/55	0,34/0,27/0,24	910/820/720	39/34/32	4,5

### DIMENSIONS mm

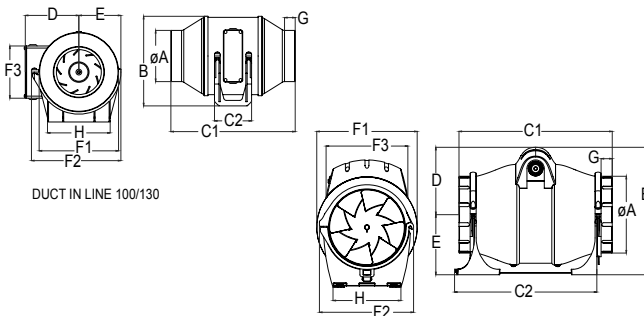

	Ø A	B	C1	C2	D	E	F1	F2	F3	G	H
DUCT IN LINE 100/130	98	171,5	238	71	102,5	80,5	152	171	100	20	120
DUCT IN LINE 100/270	98	232	315	241,6	117	115	168	180	155	25	130
DUCT IN LINE 125/320	122	232	279	241,6	117	115	168	180	155	25	130
DUCT IN LINE 150/560	147	244	293,4	272,4	129	115	192	180	158	21	130
DUCT IN LINE 160/560	157	244	312,6	272,4	129	115	192	180	158	23	130
DUCT IN LINE 200/910	197	278,5	353,6	272,4	138,5	140	211	230	161,5	51,5	142



In line fans with  
soundproof box.

## BOX IN LINE



**IP-44**

### Box:

- Sheet steel box.
- Thermal and acoustic insulation.
- Inspection door for easy access to motor and maintenance.
- Outlets according current norms and with rubber gasket in order to.
- Mounting feet for easy installation on ceiling of wall.
- Terminal box outside.

### Housing:

- High efficient centrifugal fan (polypropylene) with aerodynamical design. (1)

### Motor:

- External rotor, **IP-44** insulation class **B**.
- 230V 50Hz/60Hz.
- Speed controlled (not in TIMER versions).
- Maximum working temperature +50°C.

### Impeller:

- Forward curved impeller directly mounted on motor shaft.

### Accessories:

- Electrical speed controllers **REGM**.

CODE	MODEL	EAN CODE	Speed (r.p.m)	Input Power (W)	Max. Amps (A)	Maximum AirFlow (m <sup>3</sup> /h)	Sound Pressure Level dB(A)	Weight (kg)
00722000	<b>BOX IN-LINE 100</b>	8422248018081	2.220	0,08	0,65	300	29	6
00723000	<b>BOX IN-LINE 125</b>	8422248018098	2.220	0,08	0,65	420	29	6
00724000	<b>BOX IN-LINE 150</b>	8422248018104	2.220	0,23	1,05	580	38	7
00725000	<b>BOX IN-LINE 200</b>	8422248018111	1.280	0,10	0,75	890	42	9

### DIMENSIONS mm

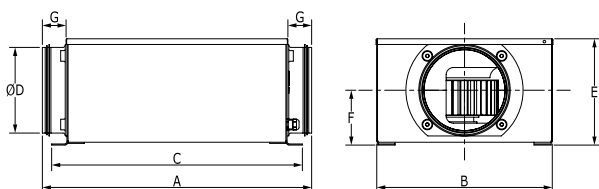

	A	B	C	Ø D	E	F	G
BOX IN-LINE 100	505	285	419	100	166	86	70
BOX IN-LINE 125	445	285	419	125	166	86	40
BOX IN-LINE 150	471	309	439	150	186	96	42
BOX IN-LINE 200	530	404	484	200	246	124	50

## Duct fans for installation in rigid and flexible tubes.

### MT



- Very silent fans.
- Plastic housing and impeller.
- All models and versions fitted with 220-240V 50/60Hz motors, **IP-X2** protection and class **B** as standard.
- Mounting support for 100 and 100 T is optional.
- White finishing.

CODE	MODEL	EAN CODE	VERSION	Ø (mm)	Voltage (V)	Speed (r.p.m)	Input Power (W)	Maximum AirFlow (m³/h)	Sound Pressure Level dB(A)	Weight (kg)	Units per box
<b>SERIE TIMER</b>											
00711000	MT-100 T	8422248920513	●	100	230	2500	15	98	41	0,4	10
<b>SERIE ESTANDAR</b>											
00710000	MT-100	8422248920186	●	100	230	2500	15	98	41	0,4	10
00720000	MT-125	8422248920520	●	125	230	2450	20	190	43	0,6	10
00730000	MT-150	8422248920797	●	150	230	2100	25	320	45	1,2	5

#### DIMENSIONS mm

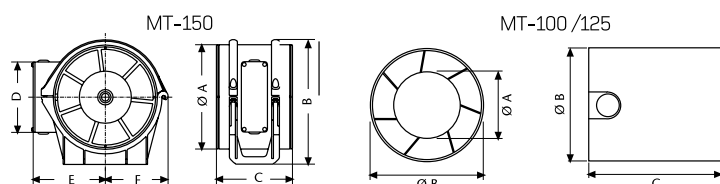

	Ø A	B	C	D	E	F
MT-100	60	97	92	-	-	-
MT-125	65	118	96	-	-	-
MT-150	148	177	108	100	99,5	89,2



Duct fans with installation kit to be installed in ductings with flexible and rigid tubes.

### KIT IN LINE

- Composed by MT series, flexible PVC ducts and two fixed plastic grills.
- Plastic housing and impeller.

CODE	MODEL	EAN CODE	VERSION	Ø (mm)	Voltage (V)	Speed (r.p.m)	Input Power (W)	Maximum AirFlow (m³/h)	Sound Pressure Level dB(A)	Weight (kg)	Units per box
<b>SERIE TIMER</b>											
00711100	KIT IN LINE 100 T	8422248920216	●	100	230	2500	15	98	41	1,10	10
<b>SERIE ESTANDAR</b>											
00710100	KIT IN LINE 100	8422248920209	●	100	230	2500	15	98	41	1,10	10
00720100	KIT IN LINE 125	8422248920612	●	125	230	2450	20	190	43	1,83	10
00730100	KIT IN LINE 150	8422248920803	●	150	230	2100	25	320	45	2,10	5

#### DIMENSIONES

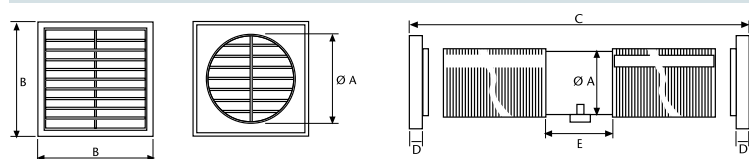

	Ø A	B	C	D	E
KIT IN LINE 100	100	140	3.000	15	92
KIT IN LINE 125	124	140	3.000	18	106
KIT IN LINE 150	150	175	3.000	15	108

### Versions



**STANDARD**  
In combination with light, fans switches on.



**TIMER**  
Electronic timer adjustable from 3 to 15 minutes.

# WALL FANS

Helicoidal fans to be installed in walls or windows.

**LHV**



- Modern design.
- Impeller with low noise profile and high efficiency.
- Window kit included.
- Protection guard on inlet side.
- Series with 230 V, 50 motor, protection **IP-44**, insulation class **B** (type 160 IP-X4).
- Speed controlled.
- Working temperature from: -20°C to +50°C.

CODE	MODEL	EAN CODE	Ø (mm)	Voltage (V)	Speed (r.p.m)	Input Power (W)	Maximum AirFlow (m³/h)	Sound Pressure Level dB(A)	Weight (kg)	Units per box
00660000	LHV 160	8422248009324	160	230	1750	20	450	40	1,2	1
00661000	LHV 190	8422248009331	190	230	1500	30	700	42	1,7	1
00662000	LHV 225	8422248009348	225	230	1150	45	900	44	3	1
00663000	LHV 300	8422248009355	300	230	1050	50	1450	47	3,4	1
00664000	LHV 350	8422248009362	350	230	1300	100	1850	52	4,3	1
00665000	LHV 400	8422248009379	400	230	1400	215	3150	55	7,4	1

## DIMENSIONS mm

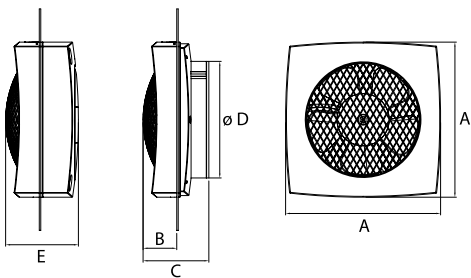

	A	B	C	Ø D	E
LHV 160	210	46	89	160	99
LHV 190	250	54	97	194	109
LHV 225	285	61	110	229	123
LHV 300	370	77	125	315	144
LHV 350	430	85	142	365	159
LHV 400	490	95	160	415	181

Helicoidal fans to be installed in walls or windows.

## B-23 / B-30



- Elegant design.
- Glass installation kit included as standard.
- Protection guard on inlet side.
- Fitted with 230V 50 Hz motors, **IP-X4** protection and class **B** as standard.
- Fully adjustable.
- Working temperatures from -20°C to +50°C.
- Model **B**: MATIC (with automatic blind).
- **RA**: Reversible with 5-speed adjuster.

CODE	MODEL	EAN CODE	Ø (mm)	Voltage (V)	Speed (r.p.m)	Input Power (W)	Max. Amps (A)	Maximum AirFlow (m³/h)		Sound Pressure Level dB(A)	Weight (kg)	Units per box
								extract	intake			
00610000	<b>B-23</b>	8422248120234	230	230	1350	45	0,19	825	530	49	5,19	1
00620000	<b>B-30</b>	8422248120241	305	230	1260	90	0,39	1900	700	51	7,45	1
00611003	<b>B-23 RA</b>	8422248007740	230	230	1350	45	0,19	825	530	49	5,19	1
00621003	<b>B-30 RA</b>	8422248007764	305	230	1260	90	0,39	1900	700	51	7,45	1

### DIMENSIONS mm

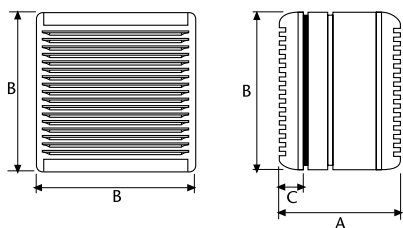

	A	B	C
B-23/RA	190	340	40
B-30/RA	230	420	40

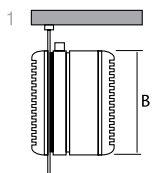

# KITCHEN EXTRACTION

Centrifugal extract fan for kitchens.

## PROFESSIONAL 750/750L/500



PROFESSIONAL 750/750L

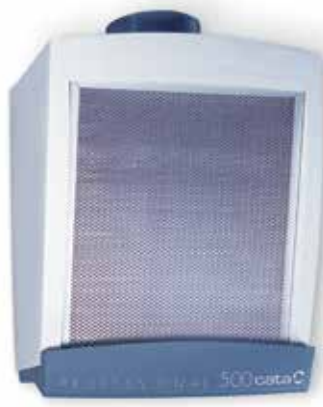

PROFESSIONAL 500

- High air flow capacity.
- High efficient centrifugal impeller.
- Metal grease filter.
- Easy to install and clean.
- 750 model with metal housing and plastic impeller.
- 500 model with plastic housing and impeller.

CODE	MODEL	EAN CODE	Ø (mm)	Voltage (V)	Speed (r.p.m)	Input Power (W)	Maximum AirFlow (m³/h)	Sound Pressure Level dB(A)	Weight (kg)	Units per box
00117000	PROFESSIONAL 750	8422248100816	120	230	1.200	125	700	49	5	3
00117100	PROFESSIONAL 750 L	8422248100823	120	230	1.200	125	700	49	5	3
00117400	PROFESSIONAL 500	8422248010832	100	230	1.900	150	450	57	2,09	4

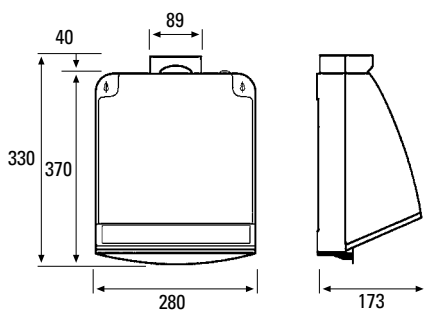

PROFESSIONAL 750/750L

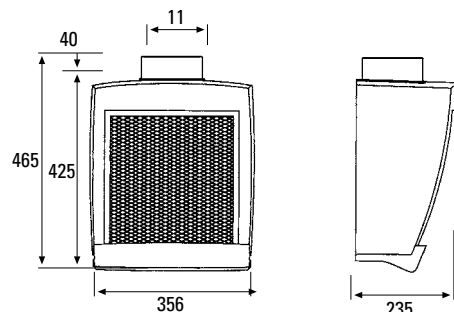

PROFESSIONAL 500

Dimensions in mm



## Centrifugal extract fan for kitchens.

# 600 PLUS 2V / GS 600



- High air flow capacity.
- Metal housing and high performance plastic impeller.
- Plate to collect grease.
- Easy to install and clean.
- The 600 Plus model incorporates a 2 speeds switch that can be wall mounted.
- Metallic grease filter in GS 600 PLUS and protection guard in GS 600.

CODE	MODEL	EAN CODE	Ø (mm)	Voltage (V)	Speed (r.p.m)	Input Power (W)	Maximum AirFlow (m³/h)	Sound Pressure Level dB(A)	Weight (kg)	Units per box
00116110	600 PLUS 2 VEL.	8422248006316	120	230	1.185	105	420/600	52	4	4
00116002	GS 600	8422248100601	110	230	1.180	105	480	50	4,8	4

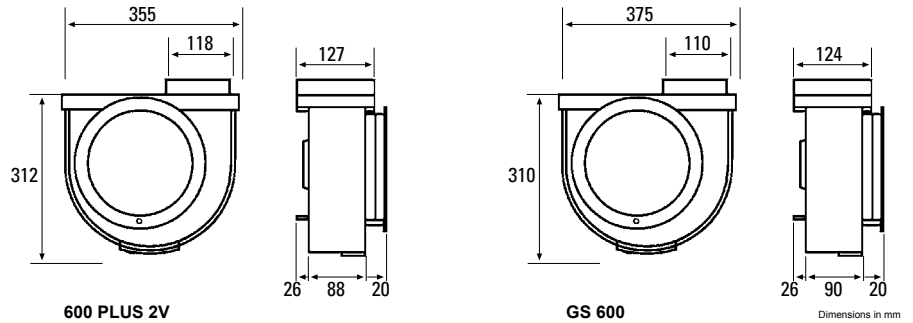

# GS 400M / GS 400P



- GS 400 M with metal housing GS 400 P with thermal plastic housing.
- Standard protection guard in all types.
- Plate to collect grease.
- Easy to install.

CODE	MODEL	EAN CODE	Ø (mm)	Voltage (V)	Speed (r.p.m)	Input Power (W)	Maximum AirFlow (m³/h)	Sound Pressure Level dB(A)	Weight (kg)	Units per box
00114102	GS 400M	8422248100403	110	230	2.200	60	290	52	2,98	4
00111002	GS 400P	8422248100830	110	230	2.200	60	290	52	2,02	4

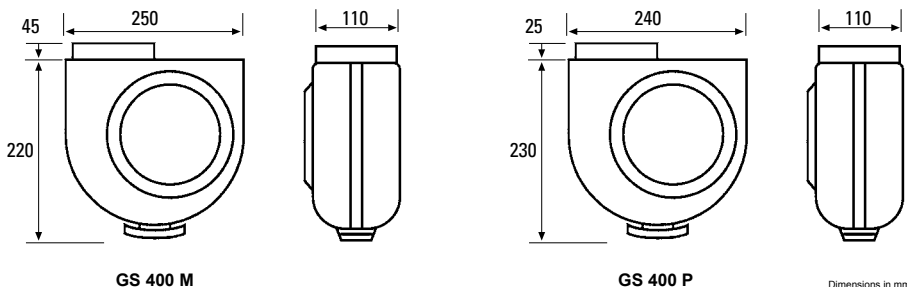

# DOMESTIC VENTILATION RANGE ACCESSORIES

CODE	MODEL	Units per Box		
01560160	LHV shutter - 160	1		
01560190	LHV shutter - 190	1		
01560225	LHV shutter - 225	1		
01560300	LHV shutter - 300	1		
01560350	LHV shutter - 350	1		
01560400	LHV shutter - 400	1		
01970000	WINDOW KIT X-MART 10	1		
01971000	WINDOW KIT X-MART 12	1		
01972000	WINDOW KIT X-MART 15	1		
01910000	WINDOW KIT B-10	1		
01920000	WINDOW KIT B-12	1		
01930000	WINDOW KIT B-15	1		
01910100	GLASS RING FIXTURE B / B MATIC / X-MART / X-MART MATIC 10	1		
01920100	GLASS RING FIXTURE B / B MATIC / B PLUS / X-MART / X-MART MATIC 12	1		
01930100	GLASS RING FIXTURE B / B MATIC / B PLUS / X-MART / X-MART MATIC 15	1		
01910200	FIXED GRILL B-10	1		
01920200	FIXED GRILL B-12	1		
01930200	FIXED GRILL B-15	1		
01910300	SHUTTER B-10	1		
01920300	SHUTTER B-12	1		
01930300	SHUTTER B-15	1		
01990097	BACKDRAUGHT SHUTTER B-10 PLUS / E-100	1		
01920600	BACKDRAUGHT SHUTTER B-12 PLUS	1		
01990094	BACKDRAUGHT SHUTTER E-120	1		
01930600	BACKDRAUGHT SHUTTER B-15 PLUS	1		
01990095	BACKDRAUGHT SHUTTER E-150	1		
01991000	MT SUPPORT-100	1		
CODE	MODEL	Voltage (V)	Protection	Units per Box
01141010	SPEED CONTROLLER	220-240	IP-44	1



LHV blind



Glass Fixing Kit



Fixed Grill



Grill on pressure



Backdraught shutter



MT support

# Performance curves

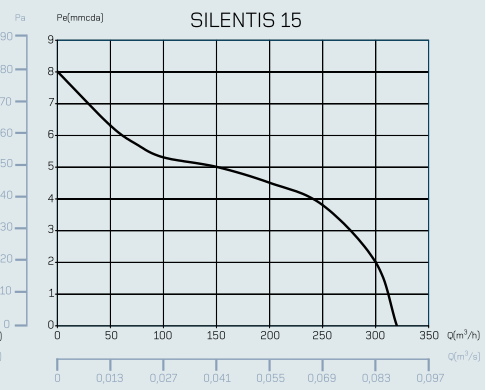
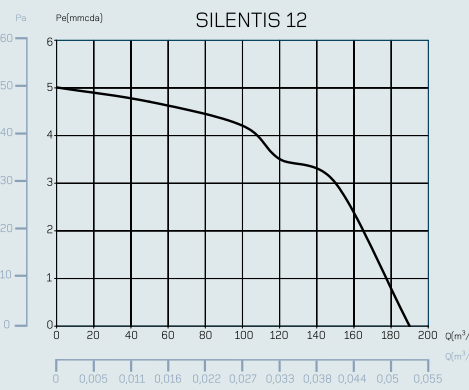
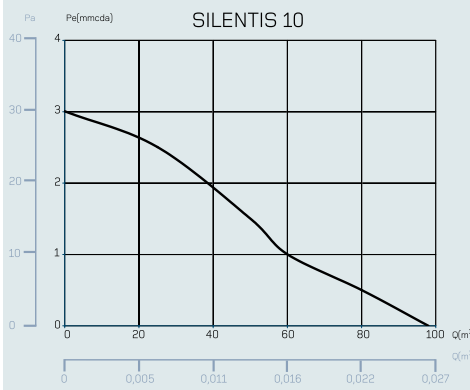
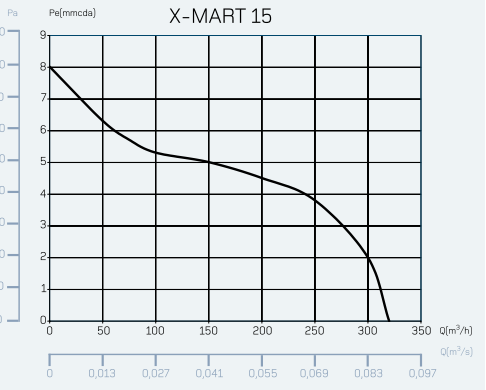
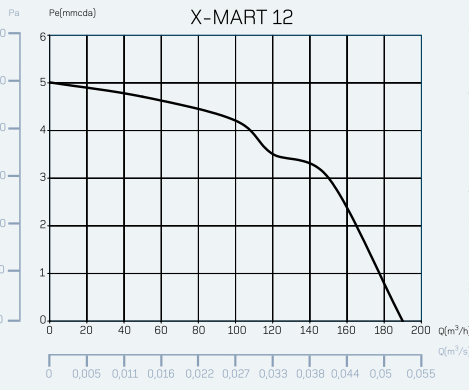
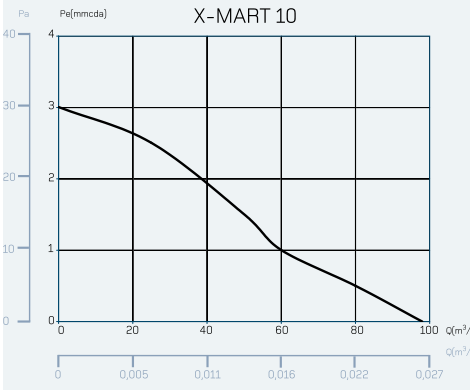
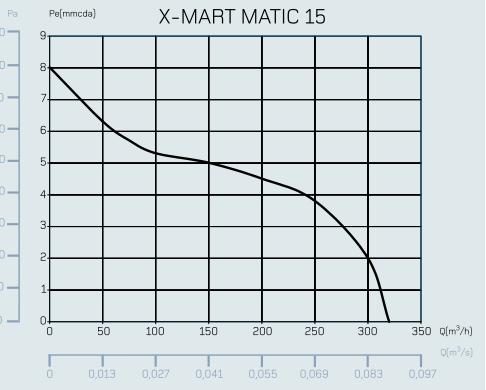
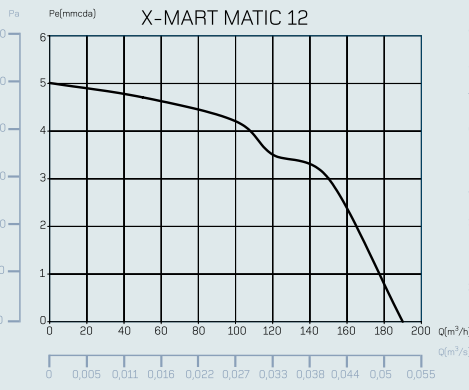
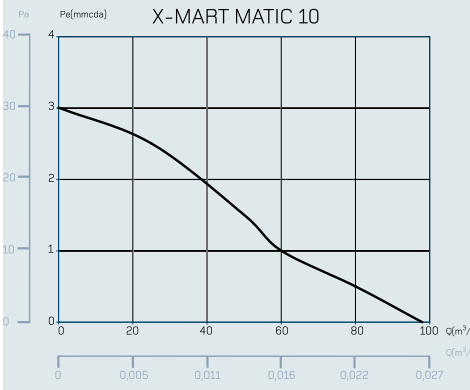
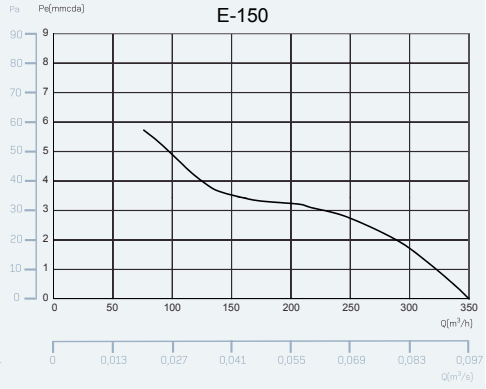
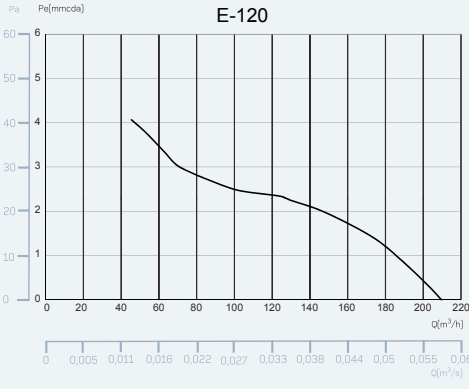
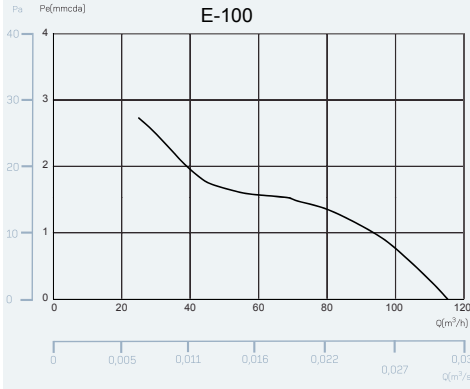

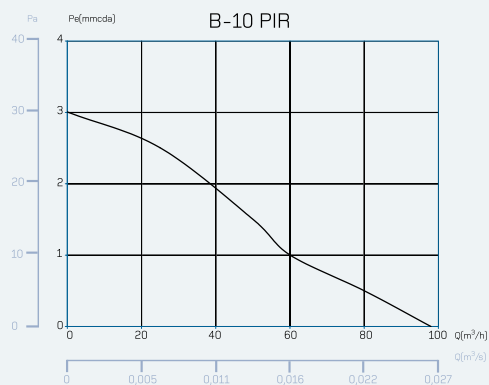
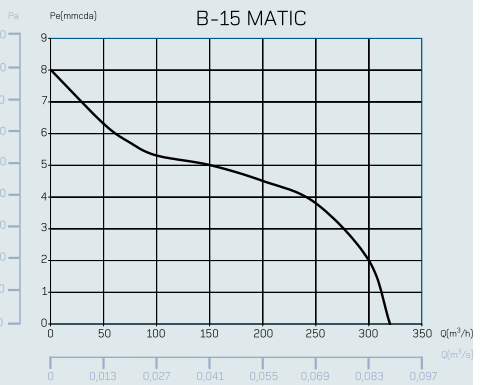
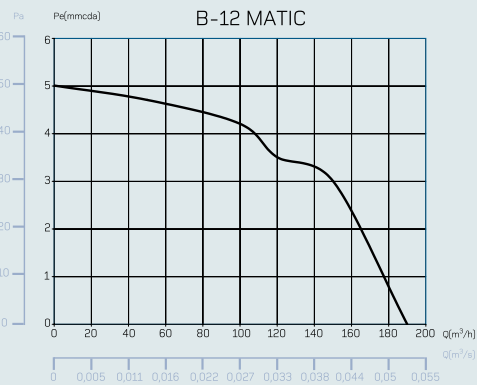
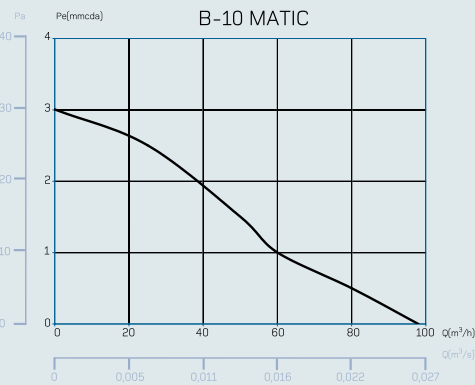
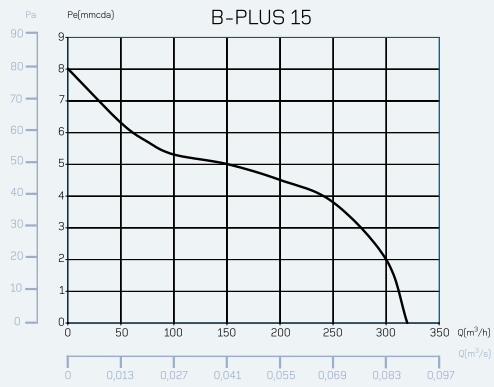
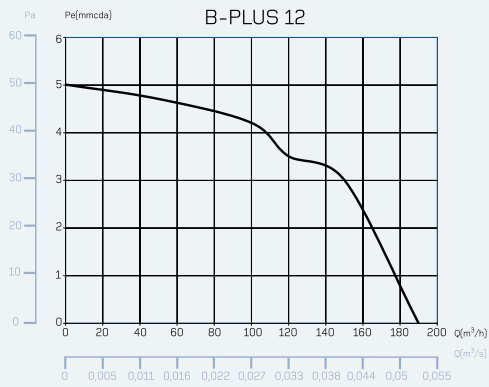
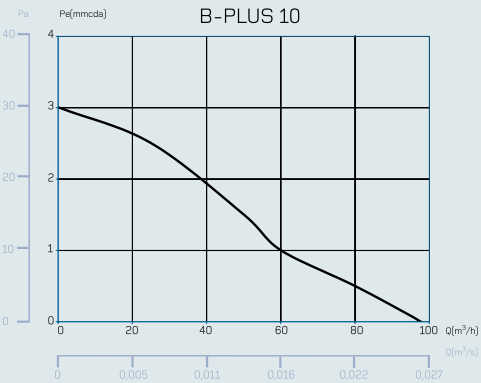
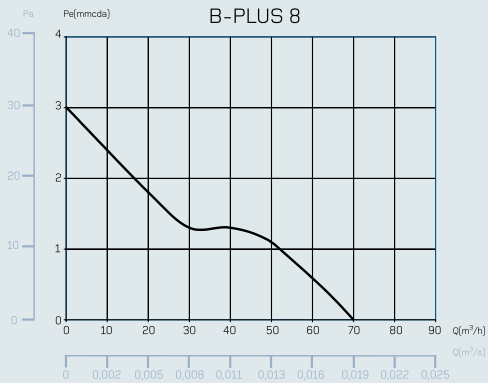

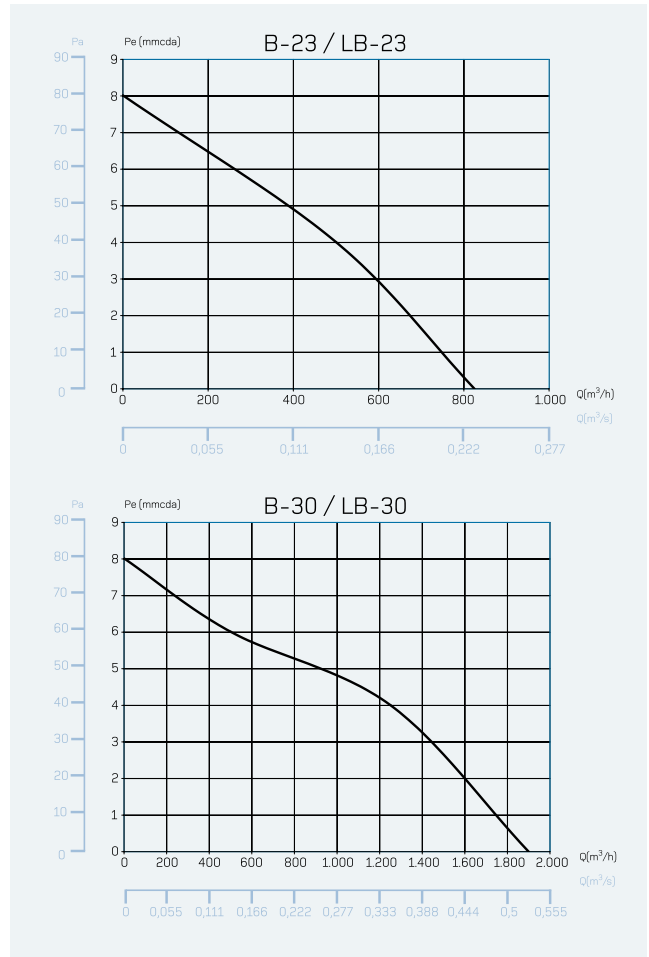
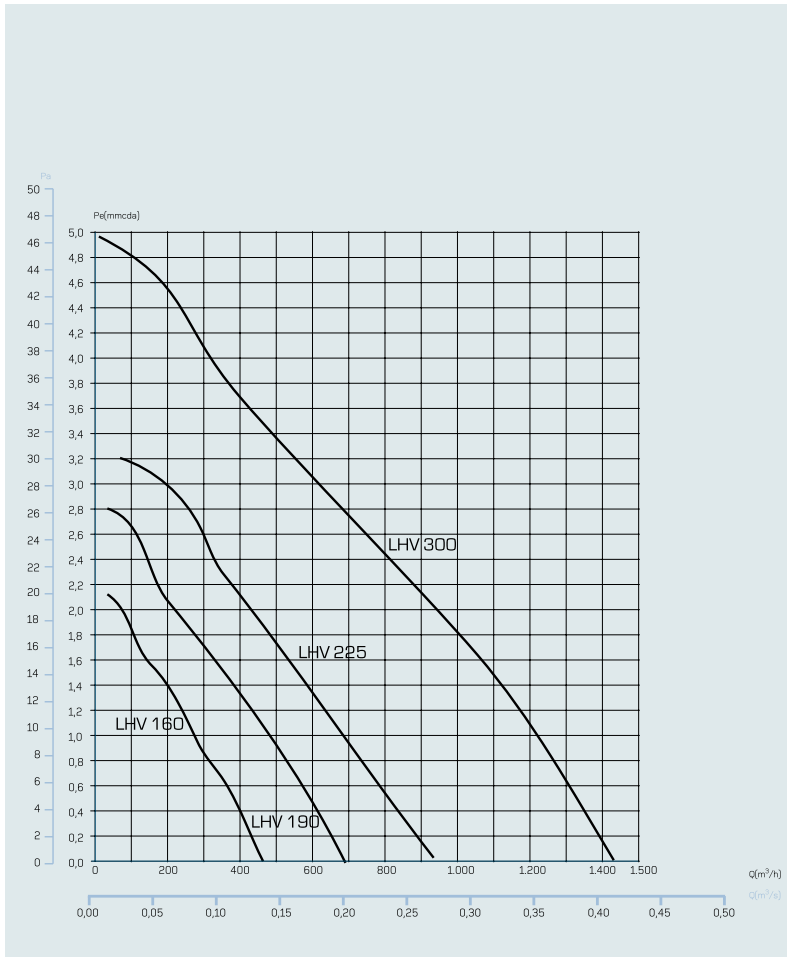
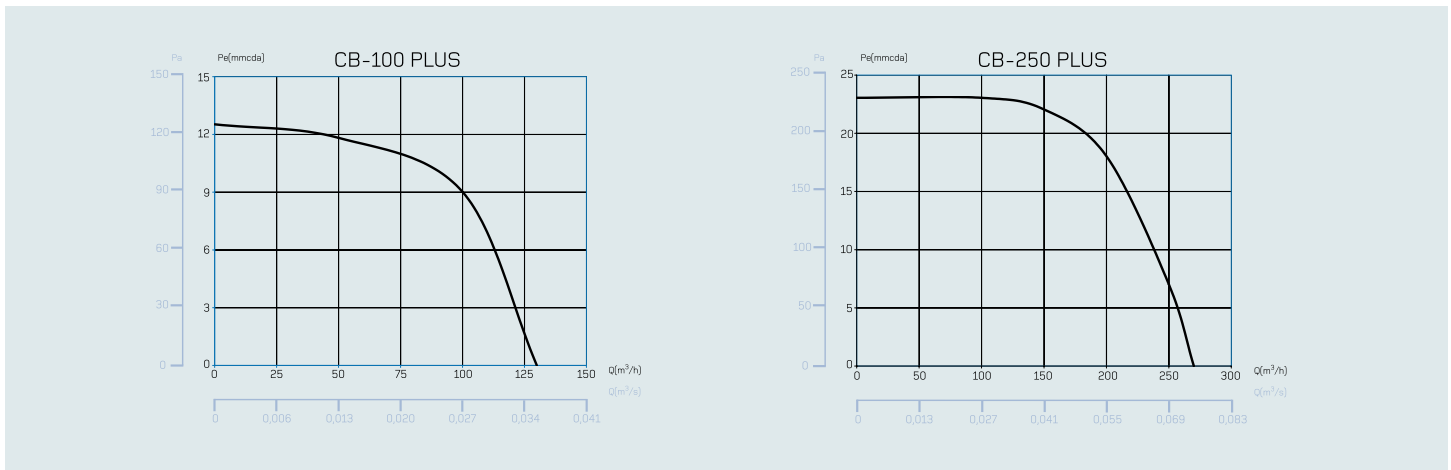
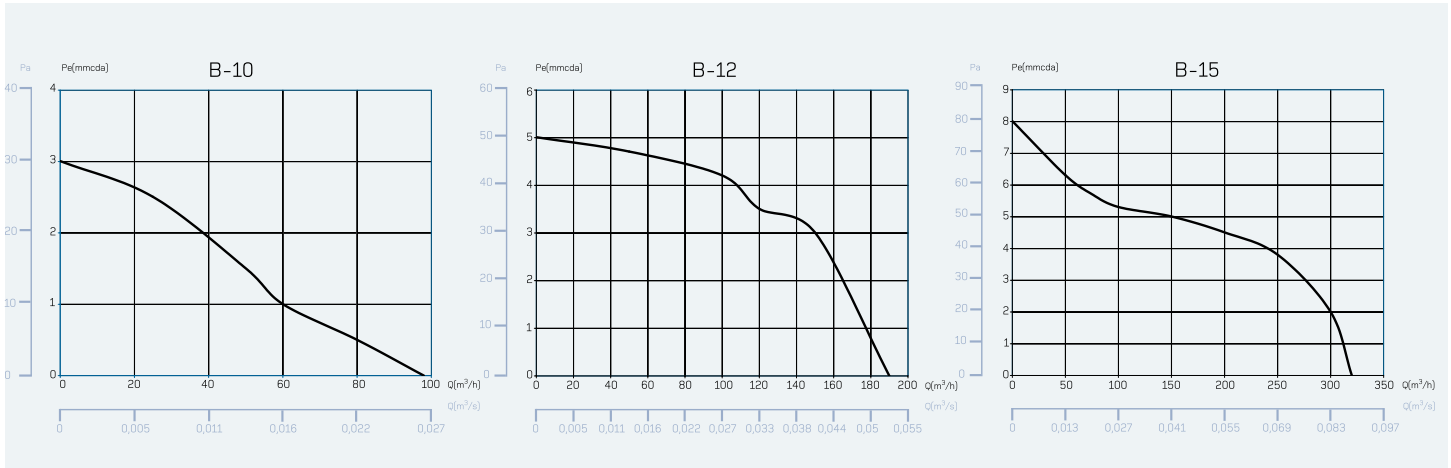

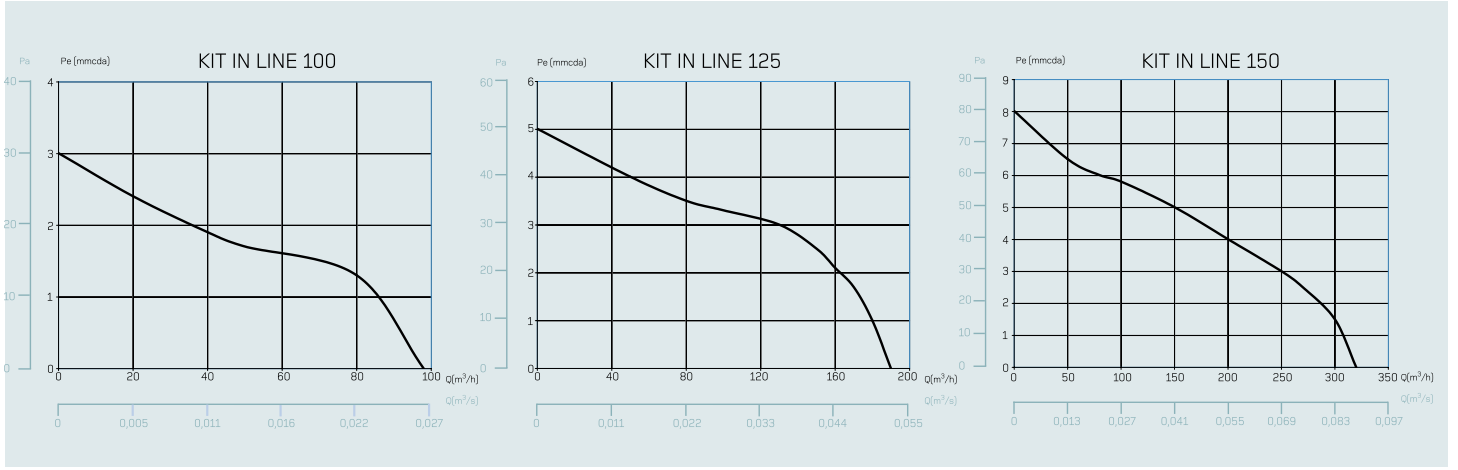
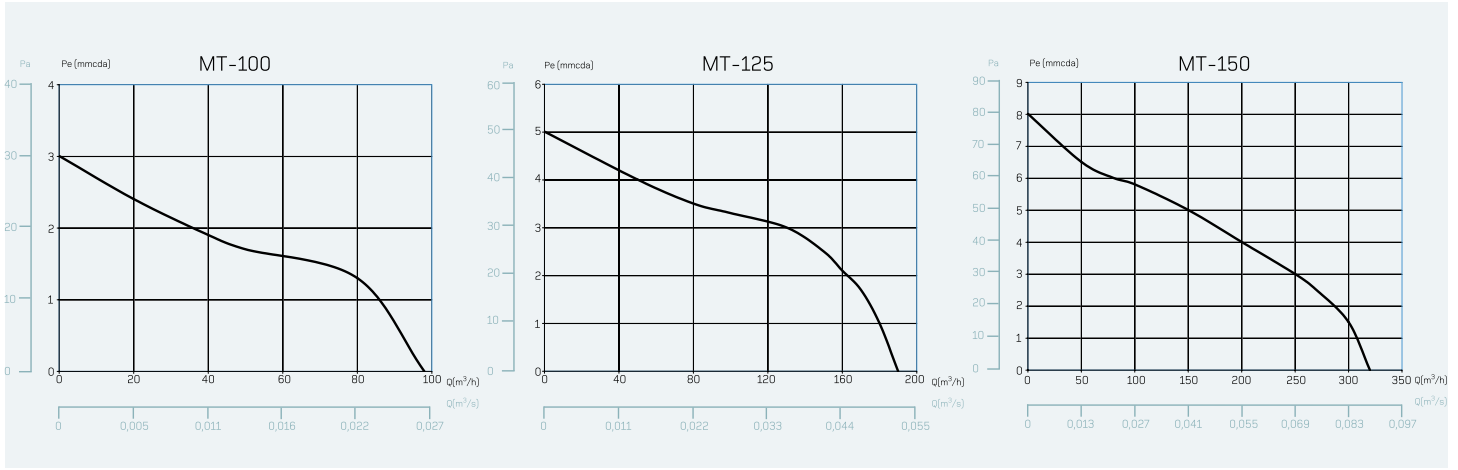

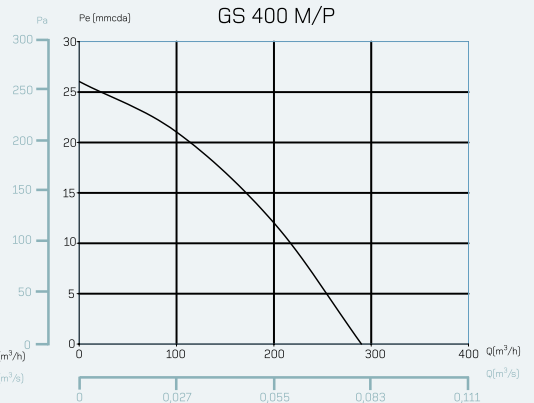
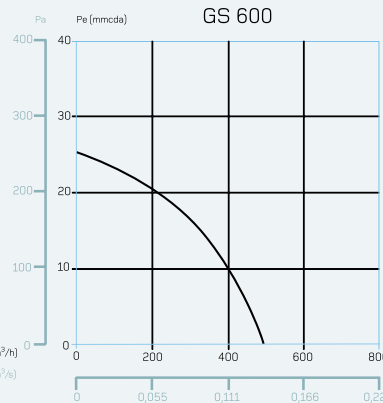
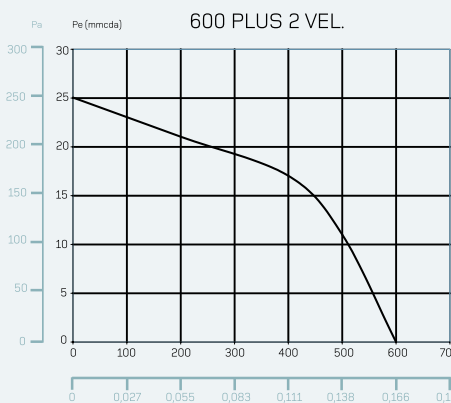
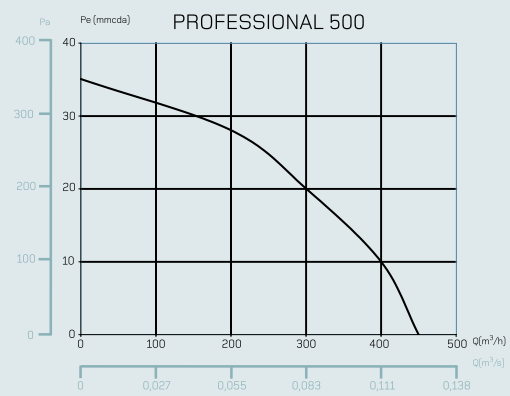
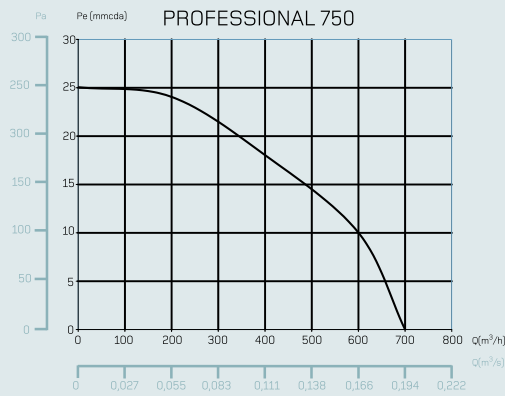
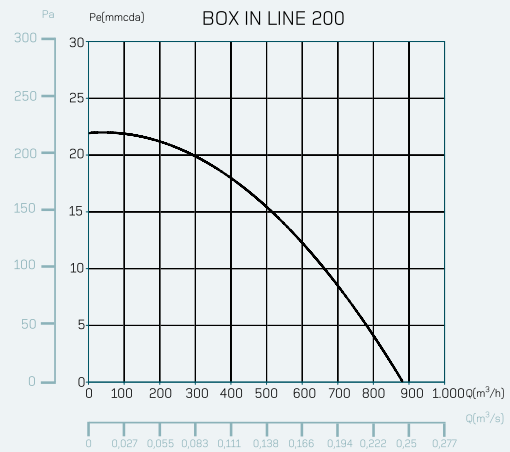
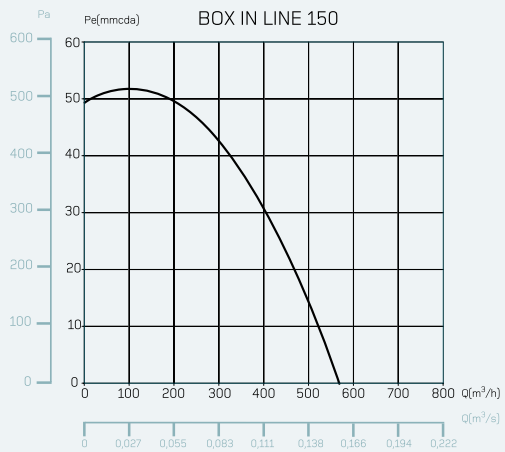
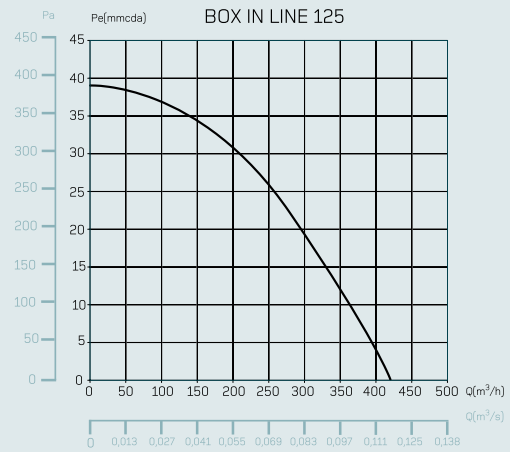
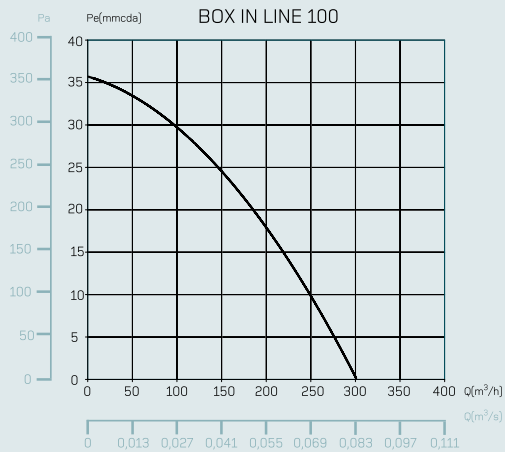

# Concepts

## BASIC VENTILATION CONCEPTS

### WHAT IS VENTILATION?

Ventilation is understood to be the replacement of a portion of air which is considered undesirable (polluted), by another that provides an improvement both in terms of purity, and of temperature, humidity, etc.

### FUNCTIONS

To maintain the air in an enclosure under suitable conditions of temperature, humidity, pressure, speed and degree of pollution to ensure the health and wellbeing of people, or living beings.

### FLOW RATE

This is the amount of air displaced in a given unit of time. (The flow given in the technical specifications is at free discharge, in other words, with no pressure loss). Flow is shown as Q and is usually expressed in m<sup>3</sup>/h, although it is also commonly expressed in m<sup>3</sup>/min, m<sup>3</sup>/sec, l/s, C.F.M

$$1 \text{ m}^3/\text{h} = 3,6 \text{ l/s}$$

$$1,7 \text{ m}^3/\text{h} = 1 \text{ C.F.M}$$

The **FLOW RATE** and the section are related as follows:

$$Q = V * S = \text{m}^3/\text{h}$$

$$V = \text{Air speed (m/sec)}$$

$$S = \text{Section (m}^2\text{) of the duct}$$

$$S = \frac{d^2 * \Pi}{4}$$

### WHAT IS PRESSURE?

It is the pushing force per surface unit that air needs to circulate and overcome the resistance of the system (pressure losses). Pressure is given in: mmH<sub>2</sub>O and Pa

$$9,8 \text{ Pa} = 1 \text{ mmH}_2\text{O}$$

### THERE ARE THREE TYPES OF PRESSURE:

**Static Pressure (Pe):** This is the force of the air in all directions on the walls of the tube, in a perpendicular direction to them.

**Dynamic Pressure (Pd):** Is the force that accelerates the air from zero to the velocity of the system. It is manifested only in the direction of the air.

There is a formula that links dynamic pressure and speed:

$$Pd = (V / 4,04)_2$$

### Speed Table with its Dynamic Pressure (table 3)

Speed (m/s)	Dynamic Pressure mmH <sub>2</sub> O
1	0.06
2	0.24
3	0.55
4	0.98
5	1.53
6	2.20
7	3.00
8	3.92
9	4.96
10	6.12
11	7.41
12	8.82
13	10.35
14	12.00
15	13.78
16	15.68
17	17.70
18	19.85
19	22.11
20	24.50
21	27.01
22	29.65

**Total Pressure:** This is the sum between the static pressure and the dynamic pressure  $P_t = P_e + P_d$

### WHAT IS NOISE?

It is the audible sound, that is propagated through the air and which is unpleasant to the receiver.

The **Sound Pressure (Lp)** level is what we really hear and it varies according to the premises and the distance between the source of the noise (extractor or fan) and the receiver.

The **Sound Power (Lw)** level is the amount of sound energy of a sound source (extractor or fan) every second and it is constant, in other words, it does not vary according to the premises or the distance from the sound source.



# Concepts

## BASIC VENTILATION CONCEPTS

Sound pressure level (dB)		
Noise	dB	Examples
DEAFENING	120	Thunder
	110	Cannon fire Steam whistle
VERY STRONG	100	Train in a tunnel
	90	Street with dense traffic
	80	Noisy factory
STRONG	70	Noisy office
	60	Medium-sized workshop
		Radio with the volume up high
MODERATE	60	Large shop Office
	50	
GENTLE	40	Public library
	30	Country road
		Scrunching up paper
		Quiet conversation
VERY GENTLE	20	Peaceful church
	10	Silent night
	0	Hearing limit

### HOW TO CHOOSE A FAN

You need to know the following parameters:

- Output
- Pressure
- Sound level
- Type of Electricity Supply

**Output (Q m<sup>3</sup>/h):** You have to determine the necessary flow according to:

1 • The recommended renewals with regard to the volume of the premises in m<sup>3</sup> and the activity there.

$$Q = m^3 * \text{Renow/h}$$

### RENEW./HOUR TABLE

Result of Health and Safety studies/Experience

#### INDUSTRIAL PREMISES

Noxious atmospheres	30-60
Goods deposit	3-6
Cast-iron	20-30
Industrial laundry	15-30
Machine room	20-30
Workshop (general)	8-10
Workshop with kilns	30-60
Tooling workshop	5-10
Paint workshop	30-60
Welding workshop	15-30
Dry cleaner	20-30

#### SERVICES SECTOR AND PREMISES

	NR/h
Classroom	2-4
Bank	3-4
Bar-café	10-12
Library	3-5
Cinema-theatre	10-15
Industrial kitchen	15-30
Canteen	5-10
Recording studio	10-12
Garage	6-8
Gym	6-12
Entrance hall	3-5
Hospitals	4-6
Public lavatories	8-15
Laundry	15-30
Offices	4-8
Baker's	20-30
Restaurant	5-10
Dance hall	6-8
Conference room	8-12
Hairdressing salon	10-15
Meeting room	4-8

2 • The recommended renewals with regard to the number of people that there are in the premises.

$$Q = n^{\circ} \text{ person} * m^3/h$$

Normal activity with no smoking	29 m <sup>3</sup> /h per person
Normal activity with smoking	58 m <sup>3</sup> /h per person
Light physical activity	45 m <sup>3</sup> /h per person
Industrial warehouses and premises	60 m <sup>3</sup> /h per person

# Concepts

## BASIC VENTILATION CONCEPTS

3● When localised extraction is required in the place where the contaminating source is, the flow (**Q**) will be determined taking the following into account:

- Surface area of the hood
- Speed of catchment
- Speed of transport by the recommended renewals system with regard to the number of people that there are in the premises.

$$Q = 3.600 \cdot V \cdot S = \text{m}^3/\text{h}$$

**Q** = Necessary air flow (**m<sup>3</sup>/h**)

**V** = Speed of catchment (**m/h**)

**S** = Hood or ducting section (**m<sup>2</sup>**)

LOCALISED EXTRACTION GUIDE COOKER HOODS			
Hood Class	Speed Catchment in m/sec On hood surface	Calculation per m <sup>2</sup> of surface area of the hood	Speed of transport m/sec
4 sides open	from 1 to 1,2 m/sec.	3.500 to 4.500 m <sup>3</sup> /h	from 6 to 10 m/sec.
3 sides open	from 0,85 to 1 m/sec.	3.000 to 3.500 m <sup>3</sup> /h	
2 sides open	from 0,75 to 0,85 m/sec.	2.700 to 3.000 m <sup>3</sup> /h	
1 side open	from 0,5 to 0,75 m/sec.	1.750 to 2.700 m <sup>3</sup> /h	



# cataC



CATA ELECTRODOMESTICOS, S.L.  
c/ del Ter, 2 - 08570 TORELLÓ (Barcelona) SPAIN  
Dpto. Com. +34 93 859 41 53  
Dpto. Export. +34 93 859 41 58

Tel. + 34 93 859 41 00  
Fax +34 93 859 41 01

[www.cnagroup.es](http://www.cnagroup.es)  
[cna@cnagroup.es](mailto:cna@cnagroup.es)